



Diamond Cutting Tools



MDC · TFC · PDC



Turning ■ Grooving ■ Boring ■ Milling



ultrahard

cutting materials

NEW!

■ TFC

The next generation of diamond cutting tools

We have TFC-Solid CVD diamond tipped tools on offer. This innovative new program of cutting tools from Becker has wear properties increasing tool life by 2-fold to 10-fold compared with PCD. This new diamond is grown in a chemical vapour deposition reactor with a thicknesses of 0.5mm - 1.8mm without binders, which allows for an extremely sharp cutting edge and thus an excellent surface finish without cutting pressure. The absence of binders at the cutting edge allows for excellent thermal conductivity which dissipates heat produced at the

cutting zone. With this technological advancement of cutting materials, the technology of tool manufacture has also evolved drastically. All segments we produce are brazed onto carbide in a high vacuum brazing process that ensures excellent quality. Due to its extreme hardness, the cutting edge cannot be ground or eroded. Therefore we have invested in high tech lasers which not only finish cutting edges of the highest quality, but which also allow 3D chip breaker lasered into various designs.

Your advantages

- First class compound materials
- Extreme hardness
- Dramatically-improved tool life
- Improved surface finish
- Reduced cutting pressure

Suitable for the following materials

- Aluminium alloys (8 - 40% Sic)
- MMC
- CRP (up to 80% carbon fibre)
- GRP (up to 80% glass fibre)
- Plastics
- Brass, copper, bronze
- Cast iron with vermicular graphite

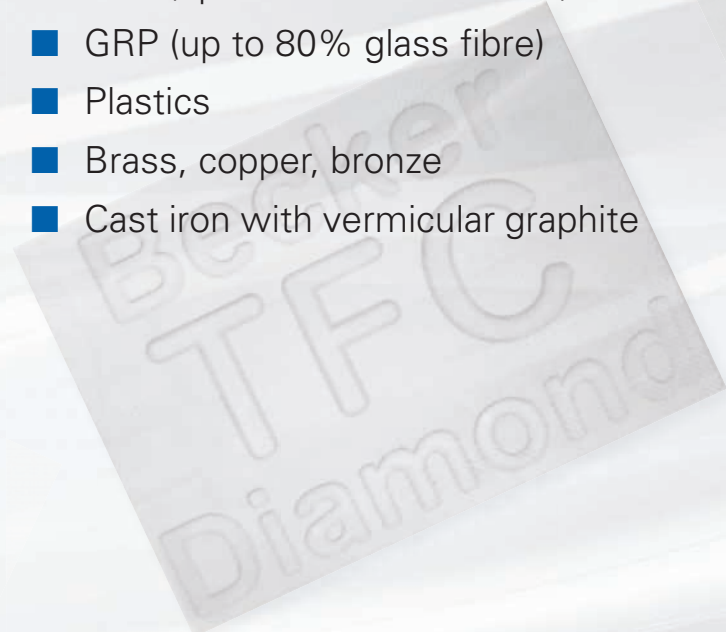



Contents

Technology

Groups of cutting material	Page	4
New ultrahard diamond cutting materials.....	Page	5
Diamond grades in comparison	Page	6
Cutting edge sharpness in comparison	Page	7
Top rake geometries.....	Page	8
Application fields for chip breaker	Page	9
Wiper cutting edge geometry and surface finish	Page	10
Recommended cutting data	Page	11
Application information	Page	12 - 13
ISO Inserts Nomenclature	Page	14 - 15



Turning

ISO inserts.....	Page	16 - 33
------------------	------	---------

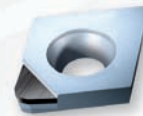

Grooving

FormCut grooving system with inserts	Page	34 - 37
--	------	---------



Boring

MiniCut boring system with inserts	Page	38 - 41
--	------	---------

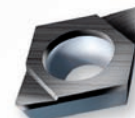

Milling

ISO milling inserts	Page	42 - 43
MillCut-TFC end mills.....	Page	44 - 45
DiaMill-SPEED, Face- and shoulder mills.....	Page	46 - 48
DiaMill-ECO, Face- and shoulder mills.....	Page	49 - 50
DiaMill-FEED, Face- and shoulder mills, with integral HSK-A63 and SK 40	Page	51 - 52
DiaMill-FLEX, Face- and shoulder mills, sizes upon request, with integral HSK-A63 and SK 40	Page	53
Spare parts for DiaMill-FEED and DiaMill-FLEX	Page	54
Milling blades for DiaMill Series	Page	55

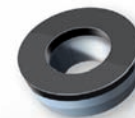

Trouble Shooting.....	Page	56
-----------------------	------	----



ultrahard

cutting materials

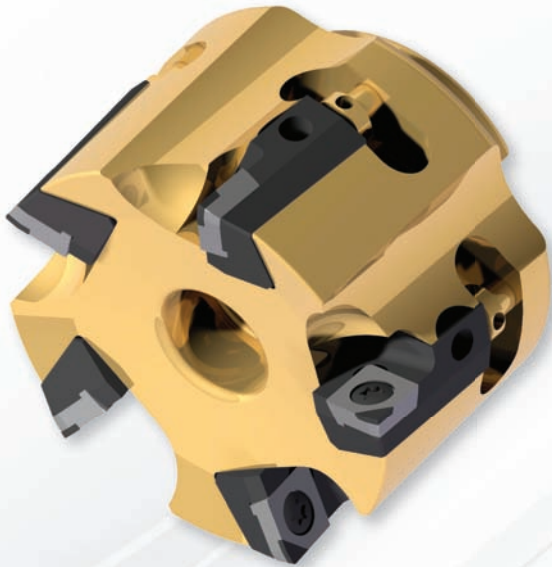

Dear customers and business partners,

The great challenges of future cutting techniques can only be mastered by ultra-hard cutting materials. For decades we have been pioneering the development and production of efficient cutting tools made of diamond and PcBN. Our tools are practically applied in all industries world-wide, for example in automotive engineering and associated suppliers, aircraft and engine construction, mechanical engineering, precision engineering and medical engineering.

On the following pages of our new catalogue we give you an exclusive introduction of our cutting tool range with diamond cutting edges: We have extended our range by two further diamond cutting materials to a total of five, which comprises the solid CVD-diamond known as our international registered trademark TFC as well as the new solid PDC-grade PDC-CU-S. It goes without saying that this will set new standards in cutting technology with diamond cutting edges. At the same time we will present the latest developments with our broad standard range of 3D-chip breaker geometries as well as the extensive application of laser technology. We would like to emphasise our unrestricted effort to research and develop new cutting technologies using diamond cutting materials.

You have any queries or suggestions, or you wish to receive our catalogue on PcBN cutting tools?

Then please feel free to contact us.

*Sincerely,
Becker Diamantwerkzeuge GmbH*

ultrahard

cutting materials



■ 2200 years of diamond research and development

From engraver to high-tech tool

For over 3000 years diamond has been known to mankind as the hardest existing mineral. Until this day it still is the most treasured gemstone in the world. Even in early times this gem, crystallised of pure carbon, was used as a tool. Archaeologists have found proof dating back 200 years BC that unprocessed diamond was used as engraver even then. Later on the polishing technology came into development for the moulding of diamond blanks. During the Second World War the demand for natural diamonds has risen unexpectedly in all industries, thus the continuing need for diamonds soon exceeded the amount extracted from natural resources.

The synthetic diamond was born

The first real synthetic diamonds were crystallised in Sweden by ASEA in 1953. The General Electric Company in the USA was second to announce the successful results of their research in 1955. Synthetic diamonds are nowadays being produced as monocrystalline stones (MDC), polycrystalline Solid-CVD blanks (TFC) and as polycrystalline diamond compound material (PCD). The global demand of these ultrahard cutting materials is on a constant rise. In all modern machining, diamonds and cubic boron nitride have become cutting materials that are simply indispensable.

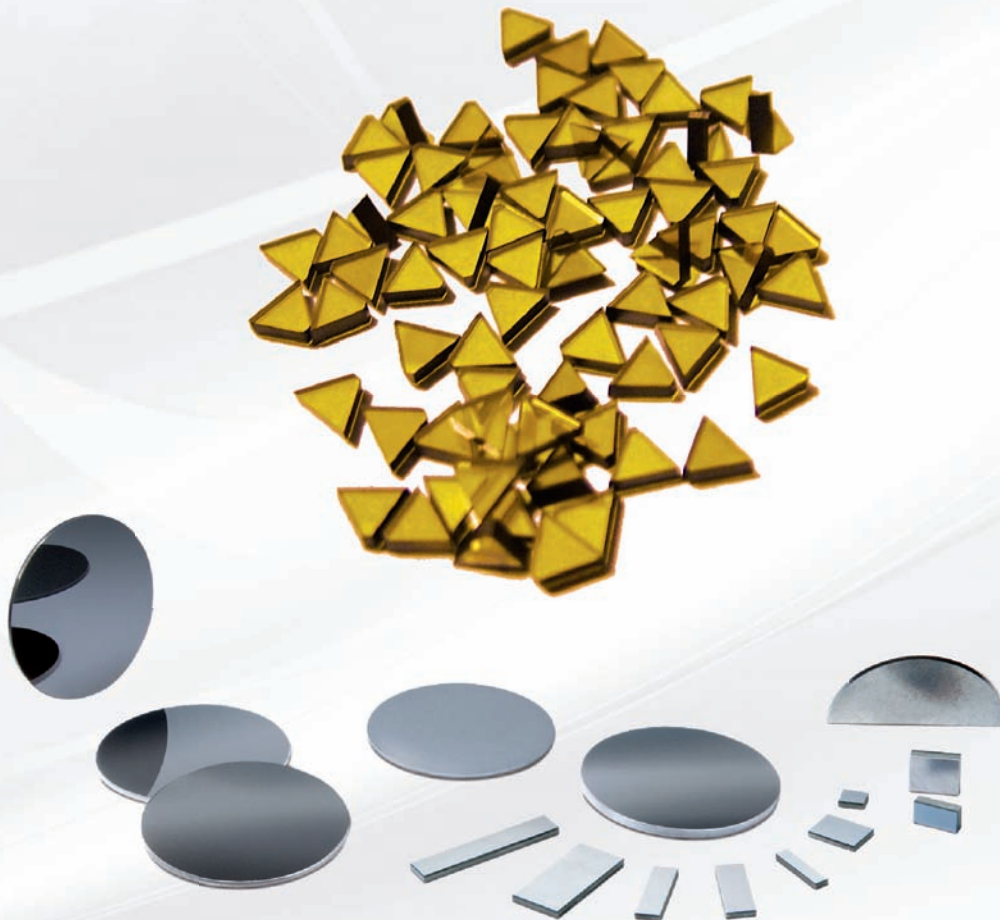



ultrahard

cutting materials

Groups of cutting materials (DIN ISO 513)

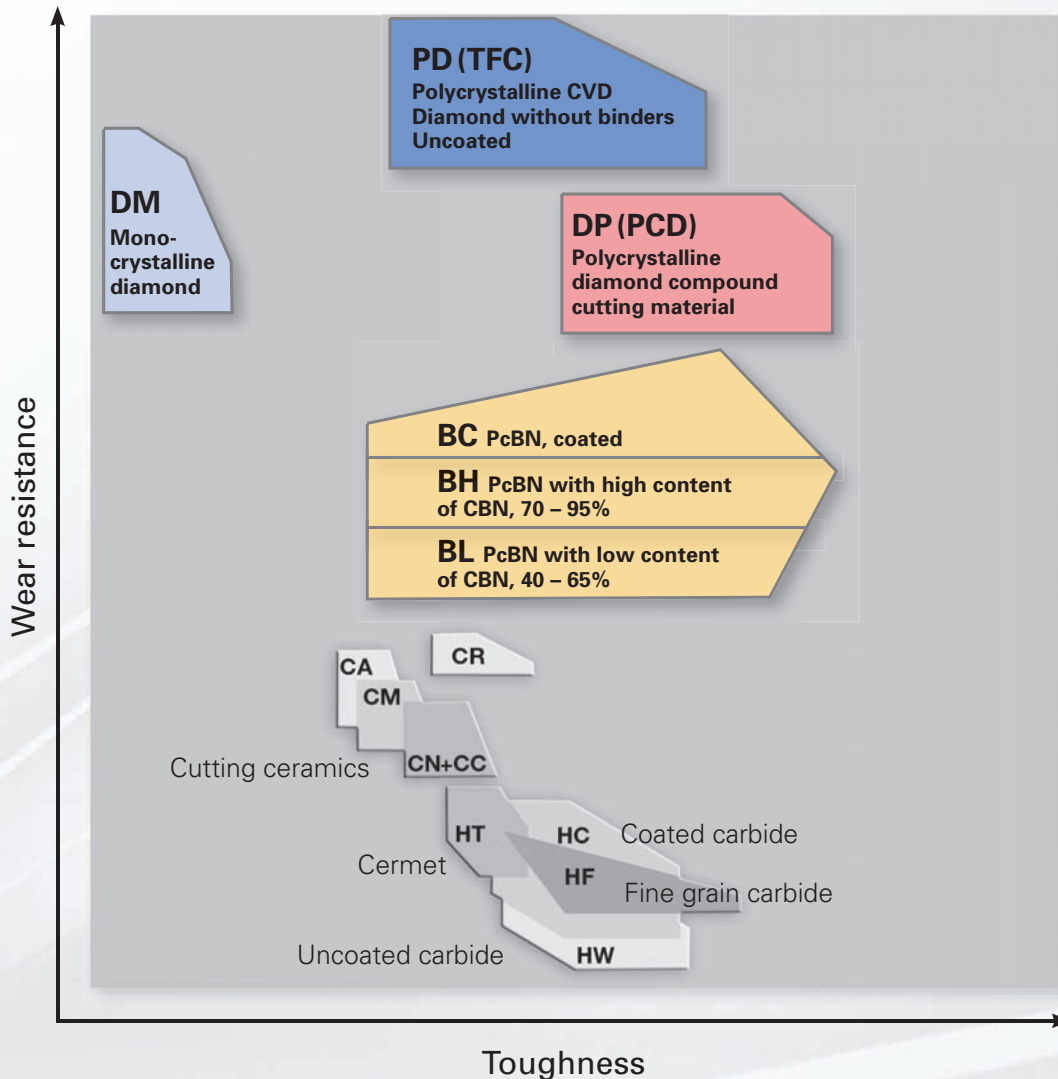

Additional ISO designation codes for carbide (also Cermet) and ceramics have been added to the DIN ISO 513 (2001) standard. Furthermore new ident letters for the ultrahard cutting materials polycrystalline cubic boron nitride, monocrystalline and polycrystalline diamond have been introduced.

<p>HW = Uncoated carbide</p> <p>HF = Fine grained carbide</p> <p>HT = Cermet, TiC or TiN</p> <p>HC = Carbide / Cermet as above, but coated</p>	<p>DM = Monocrystalline diamond</p> <p>DP = Polycrystalline diamond-compound</p> <p>PD = CVD - thickfilm diamond</p>
<p>CA = Ceramics, main content Al_2O_3</p> <p>CM = Mixed ceramics, main content Al_2O_3, plus components other than oxides</p> <p>CN = Siliconnitride ceramics, main content Si_3N_4</p> <p>CR = Ceramics, main content Al_2O_3 reinforced</p> <p>CC = Ceramics as above, but coated</p>	<p>BL = Polycrystalline Cubic Boron Nitride with low content of CBN (40 – 65%)</p> <p>BH = Polycrystalline Cubic Boron Nitride with high content of CBN (70 – 95%)</p> <p>BC = Polycrystalline Cubic Boron Nitride as above, but coated</p>



■ New ultrahard diamond cutting materials and their processing

Technical advancement never stands still. Fortunately we can present various new developments in regard to cutting tools. The diamond cutting edges will expedite the processing of nonferrous metals and plastics of all kinds into unknown dimensions.

First of all we would like to introduce new monocrystalline diamonds manufactured under the HPHT technique. The diamonds weigh between 0.8 and 3,5 carat and completely substitute the established natural diamond up to cutting edge lengths of 7mm.

Furthermore we can present the production and professional processing of polycrystalline TFC-solid CVD diamond with thicknesses between 0.5 and 1.8 mm. Since this pure diamond material without any binder cannot be eroded or economically ground, the only remaining machining procedure is the newly-developed laser technology.

The required segments are cut by laser. After the high vacuum brazing process the cutting edges are also treated by laser both in the periphery and on the top rake with or without a chip breaker geometry.

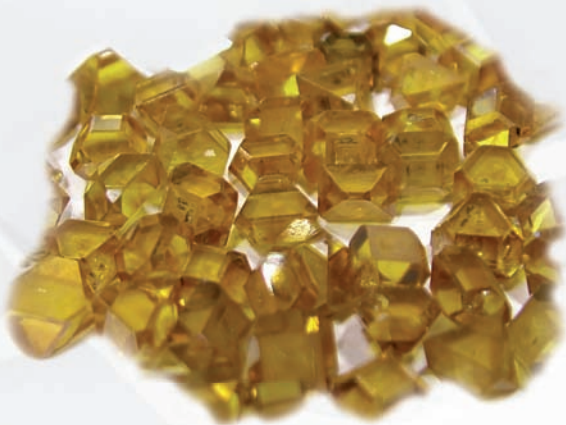

We are the world's market leader for full machining of diamond cutting edges by laser technology.

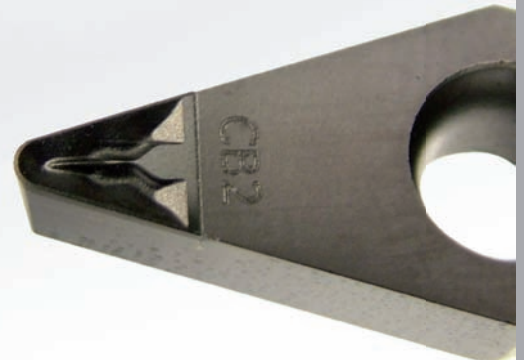
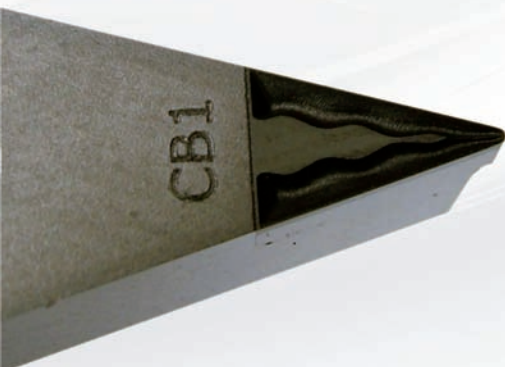



ultrahard

cutting materials

■ Diamond grades in comparison

Becker-Designation	ISO-Designation	Characteristics	Application
MDC	DM	<p>Solid monocrystalline diamond with no structure.</p> <p>Cutting edge extremely sharp and without microdamages, generating no cutting pressure, allowing burr free results with tolerances close to zero ± 0.001 mm.</p> <p>Flank extremely wear resistant and maximum thermal conductivity (HSC and HPC), low toughness.</p>	<p>Superfinishing of all pure nonferrous metals and nonmetallics with no abrasive reinforcement or silicon. (HSC-High Tech)</p>
TFC	PD	<p>Solid polycrystalline CVD-diamond without binder and without carbide reinforcement, perfect cutting edge sharpness and cutting edges without any microdamage. No cutting pressure and smallest tolerances.</p> <p>Highest wear resistance and very high thermal conductivity (HSC and HPC), higher toughness.</p>	<p>From super finishing to semi finishing of all nonferrous metals and nonferrous-composites with high content of abrasive reinforcement or silicon.</p> <p>Longest tool life on GRP (80% glass) and CFRP.</p>
PDC	DP Compound	<p>Polycrystalline diamond (compound cutting material), carbide reinforced diamond of fine grit size, good cutting edge sharpness and low cutting pressure allowing for minor tolerances.</p> <p>Lower wear resistance at higher toughness.</p>	<p>Finishing of all nonferrous metals and nonmetallics with low content of abrasive reinforcement or silicon</p>
PDC-S	DP Compound	<p>Polycrystalline diamond (compound cutting material), carbide reinforced diamond of coarse grit size, good edge sharpness and low cutting pressure allowing for minor tolerances. Ideal for milling.</p> <p>Low wear resistance at higher toughness.</p>	<p>Finishing and milling of all nonferrous metals and nonmetallics with medium content of abrasive reinforcement or silicon.</p>
PDC-CU-S	DP Compound	<p>Solid polycrystalline diamond (compound cutting material) without carbide reinforcement, coarse grit size, good cutting edge sharpness and low cutting pressure allowing for minor tolerances. Well suited for milling tools with high depth of cut.</p> <p>High wear resistance at higher toughness due to large diamond volume.</p>	<p>Finishing and milling of all nonferrous metals and nonmetallics with high content of abrasive reinforcement or silicon. Highest material removal rate.</p>

ultrahard

cutting materials



■ Cutting edge sharpness in comparison

The extreme cutting edge sharpness and its maximum diamond volume affect tool lifetime of the diamond cutting edge tremendously as a result of the extremely high thermal conductivity.

The newly developed laser technology offers great possibilities to produce such diamond cutting tools with TFC-CVD thick film and PDC diamond. Additionally all 3D geometries can be produced with the same cutting edge sharpness.

This development in laser technology and the production of the required diamond cutting materials makes us achieve our goal, which is the production of all necessary diamond cutting edges of highest quality with every optional chip control geometry without using a diamond grinding wheel.

We are among the world-wide leaders in the application of laser technology for the complete machining of diamond cutting edges.

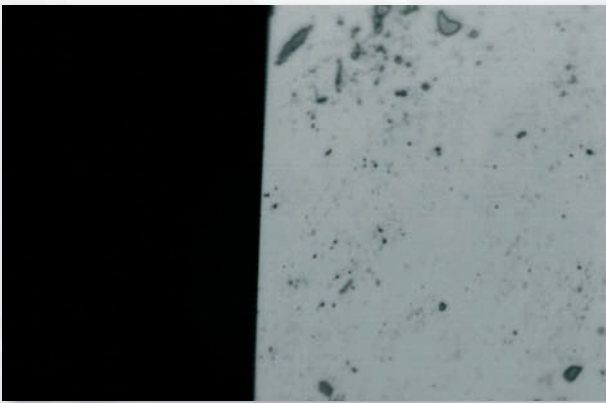

Magnification 500 x:
Monocrystalline diamond cutting edge, ground

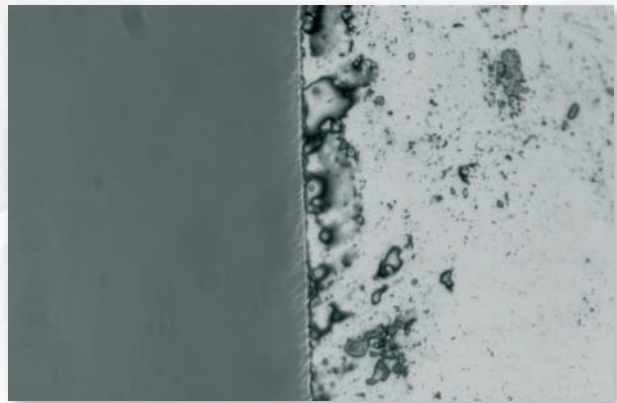

Magnification 500 x:
TFC-Solid diamond PDC-CU-S diamond,
both laser finished



Magnification 500 x:
PDC-Finest grain size, ground super fine

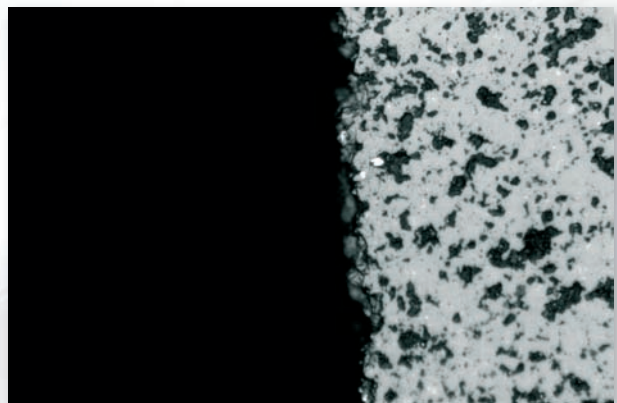

Magnification 500 x:
PDC-mixed grain size, normal grind



ultrahard

cutting materials

■ Top Rake Geometries

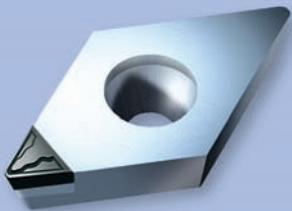
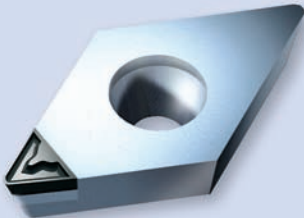
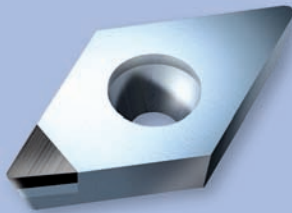
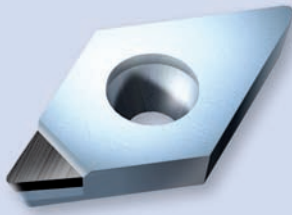
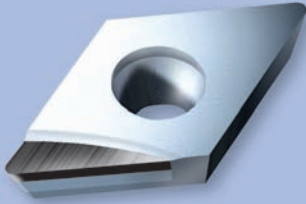
Top rake geometries		Diamond grade	Applications
	CB 1	TFC PDC PDC-S PDC-CU-S	Slight cutting pressure <ul style="list-style-type: none"> Thin-walled or instable workpieces Minor tolerances Medium surface finish Chip breakage
	CB 2	TFC PDC PDC-S PDC-CU-S	Increased cutting pressure <ul style="list-style-type: none"> Solid or firm workpieces Minor tolerances Best surface finish Chip breakage
	Neutral	MDC TFC PDC PDC-S PDC-CU-S	Medium cutting pressure <ul style="list-style-type: none"> Solid or firm workpieces Minor tolerances Very good surface finish No chip breakage, flow chip
	Positive Neutral	MDC PDC PDC-S	Minor cutting pressure <ul style="list-style-type: none"> Thin-walled or instable workpieces Minor tolerances Medium surface finish No chip breakage, flow chip
	Positive R/L	PDC PDC-S	Minor cutting pressure <ul style="list-style-type: none"> Thin-walled or instable workpieces Minor tolerances Medium surface finish High depth of cut No chip breakage, flow chip

Cutting Data - Range of chip breaker application

CB 1:

Positive geometry for finishing and super finishing, a_p : 0.05 mm to 1.5 mm. Applicable for smallest tolerances at lowest cutting pressure.

Application: thin-walled and instable workpieces.

CB 2:

Slightly negative edge preparation for roughing, semi finishing, finishing and super finishing, a_p : 0.5 mm to 2 mm. Due to an increased cutting pressure and smallest tolerances a better surface quality can be achieved.

Application: thick-walled solid workpieces under stable circumstances.

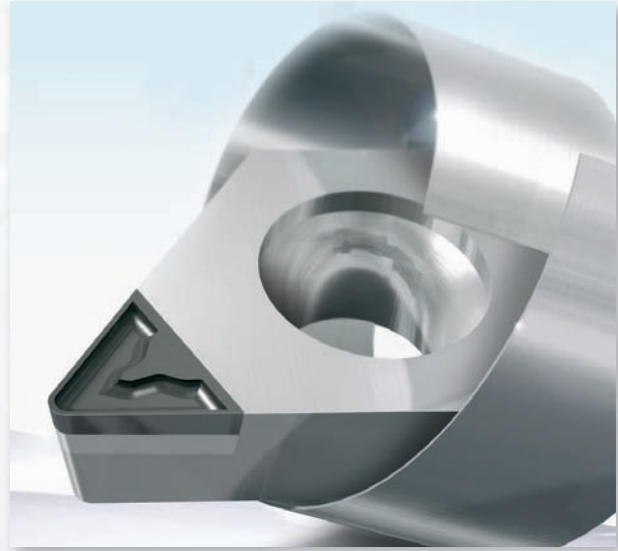

3D-chip breaker design CB1 and CB2 = 3D-Spanbrecher-Geometrien CB1 und CB2

Cutting radius	CB1 geometry				CB2 geometry				Cutting radius
	ap in mm		fz in mm/r		ap in mm		fz in mm/r		
	min.	max.	min.	max.	min.	max.	min.	max.	
0,1 mm	0,05	0,30	0,02	0,05					0,1 mm
0,2 mm	0,06	0,40	0,03	0,08	0,50	0,80	0,08	0,12	0,2 mm
0,4 mm	0,10	0,80	0,04	0,15	0,60	1,50	0,08	0,20	0,4 mm
0,8 mm	0,15	1,00	0,08	0,20	0,70	1,50	0,15	0,30	0,8 mm
1,2 mm	0,30	1,50	0,12	0,25	0,80	2,00	0,20	0,40	1,2 mm

The indicated cutting data are recommended values resulting from a chip breaker with CB 1 and CB 2 geometries. The machining should be performed without fluid coolant when PDC and PDC-S cutting edges are applied.



Without 3D-chip breaker: Flow chips



With 3D-chip breaker: Breakage chips



ultrahard

cutting materials

Wiper Cutting Edge Geometry and Surface Finish

The theoretical R_t surface roughness value can be determined with the radius and the feed rates on hand. The required surface finish can be calculated very precisely in advance, provided all relevant peripheral prerequisites are given. As an example instable conditions of machine and/or workpiece, incorrect chucking, faulty or wrong tool system, wrong cutting speed and depth of cut etc. will impair the results.

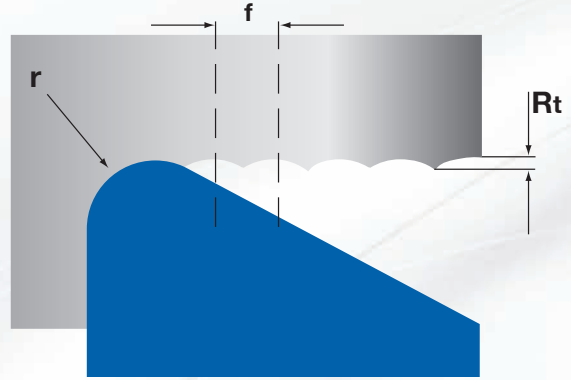

All values converted to μ

$$R_t = \frac{f^2}{8 \times r} \quad r = \frac{f^2}{8 \times R_t} \quad f = \sqrt{8 \times r \times R_t}$$

Theoretical surface roughness	Corner radius					
	R_t	Feed rate per revolution ($f = \text{mm / rev}$)				
Ra		r = 0,2	r = 0,4	r = 0,8	r = 1,2	r = 1,6
0,6	1,6	f = 0,05	f = 0,07	f = 0,10	f = 0,12	f = 0,14
1,6	4	f = 0,08	f = 0,11	f = 0,15	f = 0,19	f = 0,23
3,2	10	f = 0,12	f = 0,17	f = 0,24	f = 0,29	f = 0,36
6,3	16	f = 0,16	f = 0,22	f = 0,30	f = 0,37	f = 0,45

A clear improvement of the theoretical surface roughness can be achieved with our Wiper geometry. For the high-performance cutting of all aspects we have developed a number of inserts with WIPER geometry for internal, external and milling processes. This WIPER edge replaces the minor cutting edge reducing its angle to a minimum, whereas it automatically improves the theoretically computed surface roughness by 2 to 4 times.

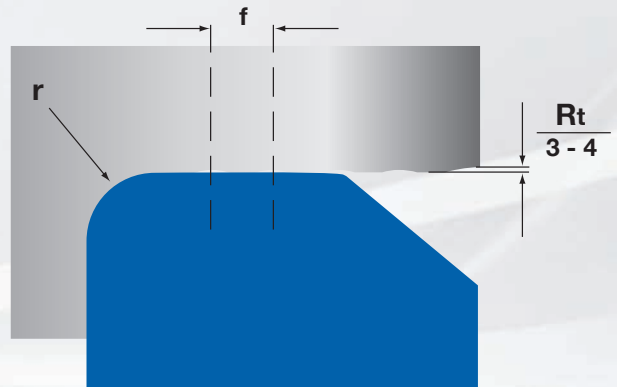

In practise these are the two possibilities for high-performance and high-tech cutting:

- 1) 2 - 4x higher feed rate = same surface finish
- 2) same feed rate = 2 - 4x improved surface finish



Recommended cutting data

Turning and milling

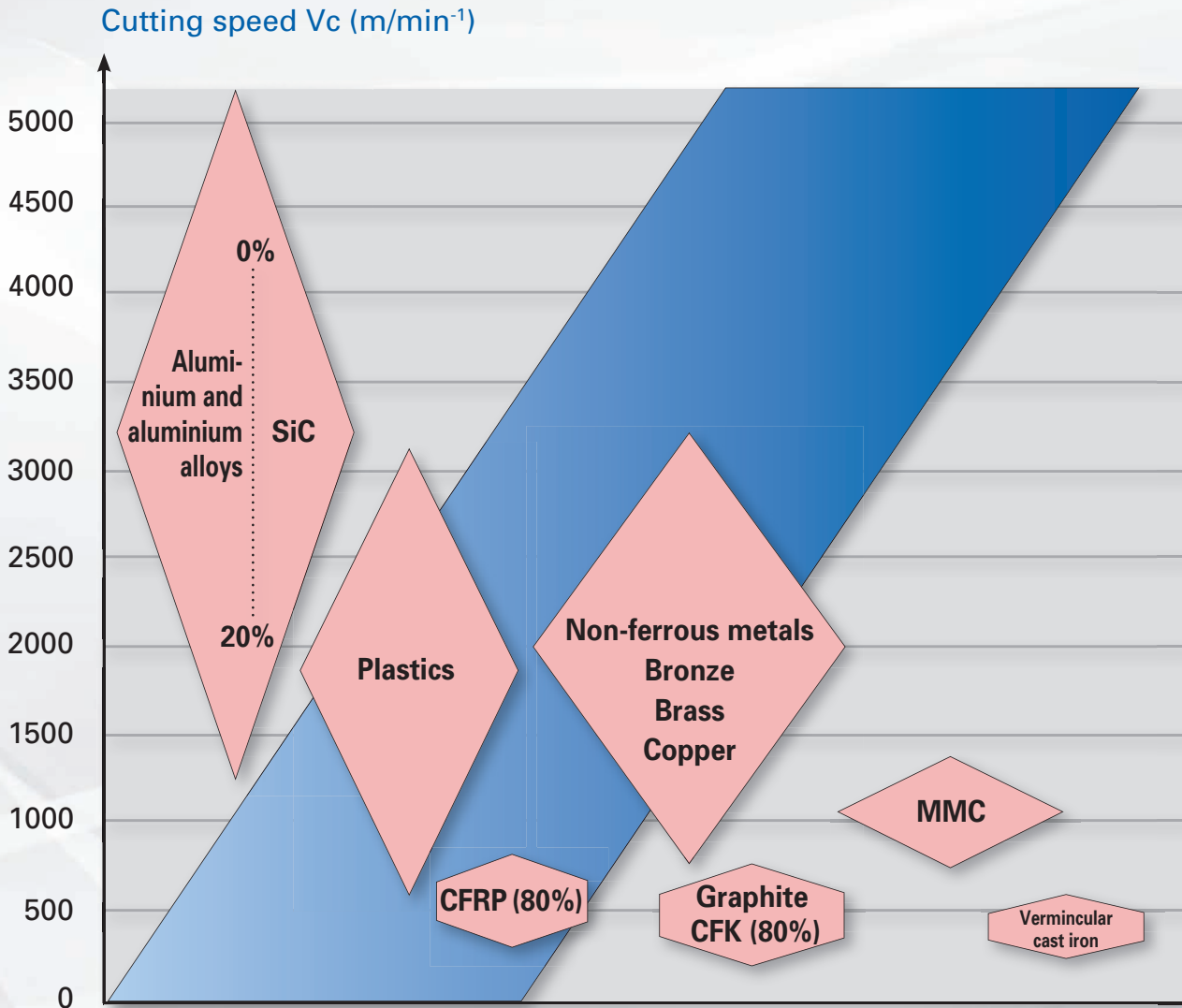

Recommended values for turning

Diamond grade	Feed rate f_z (mm/rpm)	Depth of cut
MDC	0,005 - 0,3 mm	0,005 - 1,5 mm
TFC	0,01 - 0,4 mm	0,01 - 2,5 mm
PDC	0,05 - 0,5 mm	0,05 - 3,5 mm
PDC-S	0,06 - 0,5 mm	0,08 - 5,0 mm
PDC-CU-S	0,08 - 0,8 mm	0,12 - 5,5 mm



ultrahard

cutting materials

Information

ISO turning and milling inserts

Our globally established product range of many years has on the one hand been partly condensed, but on the other hand been extended with our TFC-solid diamond and solid PDC-CU-S cutting materials including our extensive standard range of CB 1- and CB 2- 3D-chip breaker geometries. This has led to a considerably-improved performance using challenging and very abrasive working materials. Please bear in mind that we have introduced new purchasing descriptions for our ISO inserts, replacing the letter "M" by the letter "G". According to the ISO-designation code this means a tighter tolerance class. The old descriptions can certainly still be used.

FormCut grooving range

This established grooving and turning programme has also been condensed on the one hand, but on the other hand it has been extended by the TFC-solid diamond as well as the PDC-CU-S solid grade. The 3D-chip breaker geometries CB 1 and CB 2 are available in our standard range and on enquiry. This enables us to increase the performance to a considerable extent. We also wish to point out the particular stability of our FormCut system.

MiniCut boring range

Our boring range has also been condensed and extended by the TFC-solid diamond cutting material. The tools are also available with 3D-chip breaker geometries CB 1 and CB 2. This increase in performance, particularly for boring depths of $7 \times D$, are included in our standard range.

MillCut

Our MillCut range represents a new milling series tipped with the new TFC-Solid CVD diamond. All milling cutters without 3D-chip breaker geometry are in our standard range ex stock. We certainly also supply milling cutters with our 3D-chip breaker geometries CB 1 and CB 2 for special applications on enquiry. All milling cutters have a completely

solid carbide shank with internal coolant feed onto the cutting edge. The cooling system is optionally available with fluid or air feed. All TFC-cutting edges are machined by the latest finish-laser technology with h8 tolerance.

Our TFC-MillCut tools have had their baptism by fire long ago and demonstrated their impressive performance, when it comes to cutting GRP with a glass content of 80%. A long-term cutting trial of GRP with 80% glass content on customer's site has shown a 100-fold longer machining period compared with identical carbide milling cutters. This has resulted in an uncatchable superiority in performance and improvement in quality alike. This superiority can also be said for cutting CFRP with 80% carbon fibre.

DiaMill-SPEED

Our new cutting series DiaMill-Speed broadens the possibilities of high speed cutting. We apply the cutting materials TFC-solid CVD-diamond and solid PDC-CU-S as standard on our cutting inserts without 3D-geometry. If requested, we also supply the inserts with our 3D-chip breaker geometries CB 1 and CB 2. The cutters are made of 7075-T6 aluminium alloy with internal coolant feed onto the cutting edge and include the cartridges. These are factory adjusted at precisely 0.01 mm. Readjustment on site is to be avoided if possible and should only be carried out by qualified staff if need be. Our inserts type CPGW 09T304PDR-1 up to PDR-6 are precisely machined with the latest finish-laser technology and, when changed, do not require any time-wasting adjustment. The different PDR-geometries and the diamond cutting materials can be mixed up and assembled for sophisticated milling operations.

ultrahard

cutting materials



Information

DiaMill-ECO

The established cutting system DiaMill-ECO with steel body has been slightly modified and offers unbeatable value for money. We have tipped the carbide blade with our TFC-solid diamond and with solid PDC-CU-S. Enormous cutting volumes can be easily achieved with the BFLP-wiper edge and the BFEK-design with large side cutting edges for cutting depths of 4 – 6 mm. The simple but highly-efficient design with internal coolant feed demonstrates convincing stability of the carbide milling blades. The surface finish achieved with the normal flank pitch design is very good due to professional selection of the various corner radius sizes up to 1.6 mm. The precise height adjustment of the blades can be set without problem by every setting device or calliper using the adjustment screw.

DiaMill-FEED

The DiaMill-ECO system has been advanced into the DiaMill-FEED. A massive key clamp is being applied and the number of cutting edges increased by at least 50%. All complete tool types DMFS and DMFL with HSK A63 as well as SK 40 are being fine-balanced in G 2.5 quality at maximum speed. The shell type milling cutters type DMFA are supplied factory pre-balanced and have to be fine-balanced by qualified staff using the applied milling arbor. We are happy to offer you our service to do this job for you. The tight flank pitch and internal coolant feed of our cutting insert types BFLP and BFEK ensure very good surface finish in high speed cutting mode and extremely long tool life as standard. This design has been widely applied in the field of engine production for years. The improved design makes expensive monobloc tools superfluous. The precise adjustment of the cutting inserts has to be set by a setting device or calliper as with DiaMill-ECO.

DiaMill-FLEX

As a special service we have the series DiaMill-FLEX on offer, which is a special design of the DiaMill-FEED design made according to customer's enquiry. In this case the measure of length L1 and L2 are being manufactured up to a length of approx. 220 mm according to your enquiry. At the same time the cutting diameter can be varied and adjusted keeping the flank pitch unchanged.

Application of the face and shoulder milling cutter head

When applying our milling cutter heads please observe the engagement width a_e in accordance with the cutting diameter as well as the direction of the feed rate.

If possible, all PDC-inserts should be run in down-cut milling mode. In contrast our TFC-solid diamond inserts can be run in up-cut milling mode without restriction. However the feed rate has to be higher than in down-cut milling mode.

milling Ø Dc mm	milling width ae mm
40	20 - 30
50	30 - 40
63	40 - 55
80	60 - 75
100	80 - 95
125	100 - 115
160	120 - 145
200	140 - 180

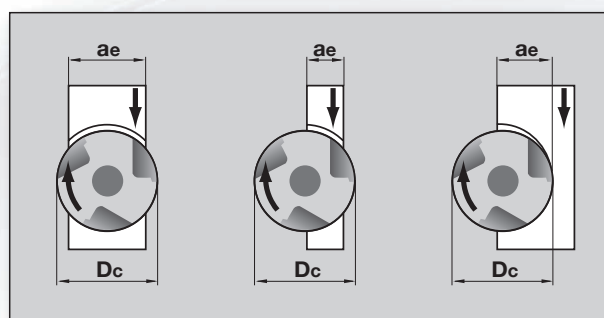

Down-cut milling shown



ultrahard

cutting materials

ISO-Insert Nomenclature

Order designation

1 Basic shape

2 Clearance

3 Tolerance class

Tolerances in mm

	m	s	d
A	0,005	0,025	0,025
F	0,005	0,025	0,013
C	0,013	0,025	0,025
H	0,013	0,025	0,013
E	0,005	0,025	0,025
G	0,025	0,130	0,025

	m	s	d ¹⁾
J	0,005	0,025	0,05 0,15
K	0,013	0,025	0,05 0,15
L	0,025	0,025	0,05 0,15
M ¹⁾	0,08 0,20	0,130	0,05 0,15
N ¹⁾	0,08 0,20	0,250	0,05 0,15
U ¹⁾	0,13 0,38	0,130	0,08 0,15

¹⁾ The exact tolerance is determined by size of insert.

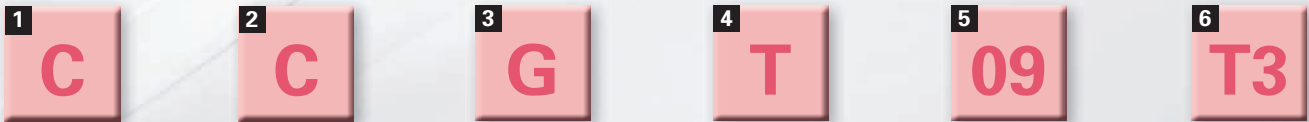

4 Insert type

N	
F	
R	
A	
G	
M	
W	
T	
X	Special design

5 Insert size

If less than 10 use 0 in first place, decimals are omitted (Example: 9,525 mm = 09)

6 Thickness in mm

01 s = 1,59	
T1 s = 1,98	
02 s = 2,38	
03 s = 3,18	
T3 s = 3,97	
04 s = 4,76	
05 s = 5,56	
06 s = 6,35	

If less than 10 use 0 in first place, decimals are omitted (Example: 3,18 mm = 03)



8

Corner configuration

Turning inserts
Wiper edge
W = Wiper edge left + right hand
WR = Wiper edge right hand
WL = Wiper edge left hand

Milling inserts
clearance of wiper edge

A	- 3°
B	- 5°
C	- 7°
D	- 15°
E	- 20°
F	- 25°
G	- 30°
N	- 0°
P	- 11°

Milling inserts
major cutting edge angle
 Major cutting edge angle

A	- 45°
D	- 60°
E	- 75°
F	- 85°
P	- 90°

ZZ = Special design, exact details are required

9

Cutting material characteristics

MDC	For best surfaces in all applications
TFC	As of 8% Si content or burr-free machining
PDC	1 – 7% Si content during continuous cut
PDC-S	1 – 7% Si content during interrupted cut
PDC-CU-S	For roughing and milling of highly abrasive materials

7
04

8
W

9
PDC

10
CB2

11
GS

7

Corner configuration

Radius

02	= 0,2 mm
04	= 0,4 mm
08	= 0,8 mm
12	= 1,2 mm
16	= 1,6 mm
00	= Round insert (inch)
M0	= Round insert (metr.)

10

Chip breaker design

CB 1	Instable workpieces
CB 2	General solid machining

11

Tipping variations

VM	
GS	



TURNING | ISO

CCGT

positive-neutral

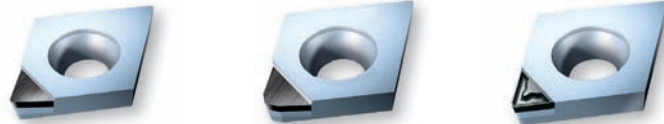

Wiper

insert size	PDC-CU-S			PDC-S			PDC			TFC			MDC	dimensions														
	Neutral	CB 1	CB 2	Neutral	CB 1	CB 2	Neutral	CB 1	CB 2	Neutral	CB 1	CB 2	Neutral															
060201				●			●									6,35	2,8	2,38	6,5				0,1	3,5	2,6			
060202				●		●	●	●			●	●								0,2	3,4	2,4	0,4	3,2	2,2	0,8	3,0	2,0
060204						●	●	●	●		●	●								0,1	3,4	2,5	0,2	3,3	2,3	0,4	3,1	2,1
060208						●	●	●	●		●	●																
060201W*				●			●																					
060202W*				●		●	●	●	●																			
060204W*						●	●	●	●		●	●																
09T302				●		●	●	●	●							9,52	4,4	3,97	9,7				0,2	4,5	2,4			
09T304						●	●	●	●		●	●								0,4	4,3	2,2	0,8	4,1	2,0	0,1	4,5	2,5
09T308						●	●	●	●											0,2	4,4	2,3	0,4	4,2	2,1			
09T301W*				●			●																					
09T302W*				●		●	●	●	●																			
09T304W*						●	●	●	●		●	●																
120404				●		●	●	●	●							12,70	5,5	4,76	12,9				0,4	4,3	2,2			
120408						●	●	●	●											0,8	4,1	2,1	0,2	4,4	2,3	0,4	4,2	2,1
120402W*				●		●	●	●	●		●	●																
120404W*				●		●	●	●	●		●	●																

* Wiper = 95° holder

CCGT

whole edge
positive neutral

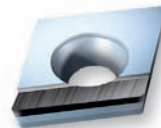

insert size	PDC-CU-S			PDC-S			PDC			TFC			MDC	dimensions										
	Neutral	CB 1	CB 2	Neutral	CB 1	CB 2	Neutral	CB 1	CB 2	Neutral	CB 1	CB 2	Neutral											
060204R/L-GS				●	○											6,35	2,8	2,38					0,4	6,45
060208R/L-GS				●	○	○														0,8	6,45			
09T308R/L-GS				●		○										9,52	4,4	3,97					0,8	9,70
09T312R/L-GS				●																1,2	9,70			
120412R/L-GS				●												12,70	5,5	4,76				1,2	12,90	



CCGW neutral

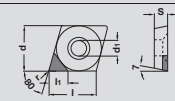

Wiper

insert size	PDC-CU-S			PDC-S			PDC			TFC			MDC	dimensions							
	Neutral	CB 1	CB 2	Neutral	CB 1	CB 2	Neutral	CB 1	CB 2	Neutral	CB 1	CB 2	Neutral								
														d	d ₁	s	l	r	PDC l ₁	TFC l ₁	
060201				●			●												0,1	3,5	2,6
060202	●			●			●			●			○						0,2	3,4	2,4
060204	●			●			●			●			○						0,4	3,2	2,2
060208													○						0,8	3,0	2,0
060201W*				●			●						○						0,1	3,4	2,5
060202W*				●			●						○						0,2	3,3	2,3
060204W*							●						○						0,4	3,1	2,1
09T302				●			●			●			○						0,2	4,5	2,4
09T304	●			●			●			●			○						0,4	4,3	2,2
09T308	●						●			●			○						0,8	4,1	2,0
09T301W*				●			●												0,1	4,5	2,5
09T302W*				●			●												0,2	4,4	2,3
09T304W*							●												0,4	4,2	2,1
120404				●			●												0,4	4,3	2,2
120408							●												0,8	4,1	2,1
120402W*				●			●												0,2	4,4	2,3
120404W*				●			●												0,4	4,2	2,1

* Wiper = 95° holder

CCGW whole edge neutral

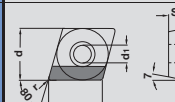

insert size	PDC-CU-S			PDC-S			PDC			TFC			MDC	dimensions						
	Neutral	CB 1	CB 2	Neutral	CB 1	CB 2	Neutral	CB 1	CB 2	Neutral	CB 1	CB 2	Neutral	 right hand shown						
														d	d ₁	s	l	r	l ₁	
060204R/L-GS							●												0,4	6,45
060208R/L-GS							●												0,8	6,45
09T308R/L-GS							●												0,8	9,70
09T312R/L-GS							●												1,2	9,70
120412R/L-GS							●												1,2	12,90



TURNING | ISO

■ CNGA neutral

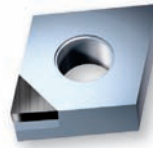

insert size	PDC-CU-S			PDC-S			PDC			TFC			MDC	dimensions					
	Neutral	CB 1	CB 2	Neutral	CB 1	CB 2	Neutral	CB 1	CB 2	Neutral	CB 1	CB 2	Neutral						
120404				●			●							d	d ₁	s	l	r	l ₁
120408	●			●			●							12,70	5,13	4,76	12,9	0,4	6,3
120412	●			●			●											0,8	6,0
																		1,2	5,7

■ CPGT positive neutral

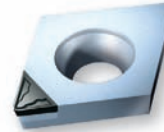
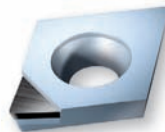

insert size	PDC-CU-S			PDC-S			PDC			TFC			MDC	dimensions					
	Neutral	CB 1	CB 2	Neutral	CB 1	CB 2	Neutral	CB 1	CB 2	Neutral	CB 1	CB 2	Neutral						
060202				●		●	●	●	●					d	d ₁	s	l	r	l ₁
060204							●	●	●					6,35	2,8	2,38	6,5	0,2	3,4
060208							●											0,4	3,2
																		0,8	3,0

CPGW neutral

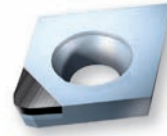
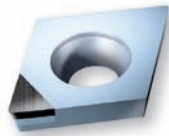

Wiper

insert size	PDC-CU-S			PDC-S			PDC			TFC			MDC	dimensions					
	Neutral	CB 1	CB 2	Neutral	CB 1	CB 2	Neutral	CB 1	CB 2	Neutral	CB 1	CB 2	Neutral						
														d	d ₁	s	l	r	l ₁
05T102				●			●							5,56	2,2	1,98	5,6	0,2	2,4
05T104							●							5,56	2,2	1,98	5,5	0,4	2,2
05T102-W*				●			●							5,56	2,2	1,98	5,5	0,2	2,4
05T104-W*							●							5,56	2,2	1,98	5,5	0,4	2,1
050202				●			●							5,56	2,5	2,38	5,6	0,2	2,4
050204							●							5,56	2,5	2,38	5,5	0,4	2,2
050202-W*				●			●							5,56	2,5	2,38	5,5	0,2	2,4
050204-W*							●							5,56	2,5	2,38	5,5	0,4	2,1
060202				●			●							6,35	2,8	2,38	6,5	0,2	3,4
060204							●							6,35	2,8	2,38	6,5	0,4	3,2
060208							●							6,35	2,8	2,38	6,5	0,8	3,0
060202-W*				●			●							6,35	2,8	2,38	6,5	0,2	3,3
060204-W*							●							6,35	2,8	2,38	6,5	0,4	3,1
09T304							●							9,52	4,4	3,97	9,7	0,4	4,3
09T308							●							9,52	4,4	3,97	9,7	0,8	4,1
09T302-W*				●			●							9,52	4,4	3,97	9,7	0,2	4,4
09T304-W*							●							9,52	4,4	3,97	9,7	0,4	4,2
120404							●							12,70	5,5	4,76	12,9	0,4	4,3
120408							●							12,70	5,5	4,76	12,9	0,8	4,1
120404-W*				●			●							12,70	5,5	4,76	12,9	0,4	4,4

* Wiper = 95° holder

CPGW neutral, whole edge

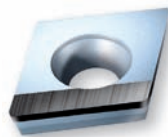

insert size	PDC-CU-S			PDC-S			PDC			TFC			MDC	dimensions					
	Neutral	CB 1	CB 2	Neutral	CB 1	CB 2	Neutral	CB 1	CB 2	Neutral	CB 1	CB 2	Neutral						
														d	d ₁	s	l	r	l ₁
060204R/L-GS							●							6,35	2,8	2,38		0,4	6,5
09T308R/L-GS							●							9,52	4,4	3,97		0,8	9,7
120408R/L-GS							●							12,70	5,5	4,76		0,8	12,9
120412R/L-GS							●							12,70	5,5	4,76		1,2	12,9



TURNING | ISO

DCGT

positive neutral



Wiper

insert size	PDC-CU-S			PDC-S			PDC			TFC			MDC	dimensions						
	Neutral	CB 1	CB 2	Neutral	CB 1	CB 2	Neutral	CB 1	CB 2	Neutral	CB 1	CB 2	Neutral	d	d ₁	s	l	r	PDC l ₁	TFC l ₁
070201				●	●	●		●										0,1	3,8	
070202		●	●	●	●	●	●	●				○	6,35	2,8	2,38	7,75		0,2	3,7	2,6
070204		●	●		●	●	●	●				○						0,4	3,4	2,3
070208						●	●	●				○						0,8	3,0	2,0
070201-LW *				●								○						0,1	3,0	2,0
070201-RW *				●								○						0,1	3,0	2,0
070202-LW *				●								○	6,35	2,8	2,38	7,75		0,2	3,0	2,0
070202-RW *				●								○						0,2	3,0	2,0
070204-LW *							●					○						0,4	3,0	2,0
070204-RW *							●					○						0,4	3,0	2,0
11T301				●	●	●		●				○						0,1	4,8	
11T302				●	●	●	●	●				○						0,2	4,7	2,6
11T304		●	●		●	●	●	●				○	9,52	4,4	3,97	11,6		0,4	4,3	2,3
11T308		●	●		●	●	●	●				○						0,8	4,0	2,0
11T312							●					○						1,2	3,5	
11T301-LW *				●								○						0,1	4,0	2,0
11T301-RW *				●								○						0,1	4,0	2,0
11T302-LW *				●								○	9,52	4,4	3,97	11,6		0,2	4,0	2,0
11T302-RW *				●								○						0,2	4,0	2,0
11T304-LW *							●					○						0,4	4,0	2,0
11T304-RW *							●					○						0,4	4,0	2,0

* Wiper R/L = 93° holder

DCGT

positive right or left hand

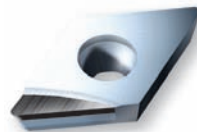

insert size	PDC-CU-S			PDC-S			PDC			TFC			MDC	dimensions							
	Neutral	CB 1	CB 2	Neutral	CB 1	CB 2	Neutral	CB 1	CB 2	Neutral	CB 1	CB 2	Neutral	d	d ₁	s	l	r	l ₁	right hand shown	
070204R/L				●			●											0,4	5,5		
070208R/L				●			●							6,35	2,8	2,38	7,8		0,8	5,0	
11T304R/L				●			●											0,4	7,5		
11T308R/L				●			●							9,52	4,4	3,97	11,6		0,8	7,0	
11T312R/L				●														1,2	6,5		



DCGW neutral



insert size	PDC-CU-S			PDC-S			PDC			TFC			MDC	dimensions							
	Neutral	CB 1	CB 2	Neutral	CB 1	CB 2	Neutral	CB 1	CB 2	Neutral	CB 1	CB 2	Neutral								
															d	d ₁	s	l	r	PDC l ₁	TFC l ₁
070201				●									○						0,1	3,8	2,7
070202				●			●			●			○	6,35	2,8	2,38	7,75		0,2	3,7	2,6
070204	●			●			●			●			●						0,4	3,4	2,3
070208	●			●			●			●			●						0,8	3,0	2,0
110302							●												0,2	4,7	
110304							●							9,52	4,4	3,18	11,6		0,4	4,3	
110308							●												0,8	4,0	
11T301				●									●						0,1	4,8	2,7
11T302				●			●			●			●						0,2	4,7	2,6
11T304	●			●			●			●			●	9,52	4,4	3,97	11,6		0,4	4,3	2,3
11T308	●			●			●			●			●						0,8	4,0	2,0
11T312				●			●												1,2	3,6	1,8
11T302-LW*				●															0,2	4,0	2,0
11T302-RW*				●															0,2	4,0	2,0
11T304-LW*				●									○	9,52	4,4	3,97	11,6		0,4	4,0	2,0
11T304-RW*				●									○						0,4	4,0	2,0
150404							●						○						0,4	4,3	2,3
150408							●						○	12,70	5,5	4,76	15,5		0,8	4,0	2,0

* Wiper R/L = 93° holder

DNGA neutral

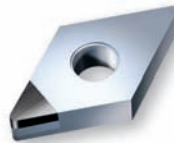

insert size	PDC-CU-S			PDC-S			PDC			TFC			MDC	dimensions						
	Neutral	CB 1	CB 2	Neutral	CB 1	CB 2	Neutral	CB 1	CB 2	Neutral	CB 1	CB 2	Neutral							
															d	d ₁	s	l	r	l ₁
150404				●			●												0,4	6,4
150408				●			●							12,70	5,13	4,76	15,5		0,8	6,0
150412				●			●												1,2	5,6
150604	●			●			●												0,4	6,4
150608	●			●			●							12,70	5,13	6,35	15,5		0,8	6,0
150612				●			●												1,2	5,6



TURNING | ISO

RCGW fullface

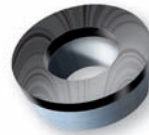

PDC

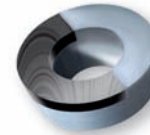

TFC

insert size	PDC-CU-S			PDC-S			PDC			TFC			MDC	dimensions											
	Neutral	CB 1	CB 2	Neutral	CB 1	CB 2	Neutral	CB 1	CB 2	Neutral	CB 1	CB 2	Neutral												
														d	d ₁	s	l	r	l ₁						
0602MO-VM				●			●													6,0	2,8	2,38			
0803MO-VM				●			●			●										8,0	3,4	3,18			
1003MO-VM							●			●										10,0	4,4	3,18			
10T3MO-VM				●			●													10,0	4,4	3,97			
1204MO-VM							●													12,0	4,4	4,76			

RCGT fullface



PDC

insert size	PDC-CU-S			PDC-S			PDC			TFC			MDC	dimensions											
	Neutral	CB 1	CB 2	Neutral	CB 1	CB 2	Neutral	CB 1	CB 2	Neutral	CB 1	CB 2	Neutral												
														d	d ₁	s	l	r	l ₁						
0602MO-VM					●	●		●												6,0	2,8	2,38			
10T3MO-VM					●	●		●												10,0	4,4	3,97			

RPGW fullface

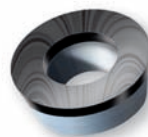

PDC

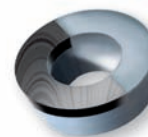

TFC

insert size	PDC-CU-S			PDC-S			PDC			TFC			MDC	dimensions											
	Neutral	CB 1	CB 2	Neutral	CB 1	CB 2	Neutral	CB 1	CB 2	Neutral	CB 1	CB 2	Neutral												
														d	d ₁	s	l	r	l ₁						
0802MO-VM								●		●										8,00	3,4	2,38			
1204MO-VM								●												12,00	5,5	4,76			
120400-VM								●												12,70	4,4	4,76			

SCGT

positive neutral



insert size	PDC-CU-S			PDC-S			PDC			TFC			MDC	dimensions					
	Neutral	CB 1	CB 2	Neutral	CB 1	CB 2	Neutral	CB 1	CB 2	Neutral	CB 1	CB 2	Neutral						
09T304				●		●		●			●	●		d	d1	s	l	r	l1
09T308				●		●		●			●	●		9,52	4,4	3,97	9,52	0,4	4,4
09T312				●														0,8	4,3
																		1,2	4,2

SCGT

positive, whole edge



insert size	PDC-CU-S			PDC-S			PDC			TFC			MDC	dimensions					
	Neutral	CB 1	CB 2	Neutral	CB 1	CB 2	Neutral	CB 1	CB 2	Neutral	CB 1	CB 2	Neutral						
09T308-GS				●										d	d1	s	l	r	l1
09T312-GS				●										9,52	4,4	3,97		0,8	9,5
120408-GS				●														1,2	9,5
120412-GS				●										12,70	5,5	4,76		0,8	12,7
																		1,2	12,0

SCGW

neutral

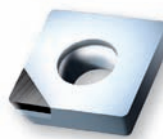

insert size	PDC-CU-S			PDC-S			PDC			TFC			MDC	dimensions						
	Neutral	CB 1	CB 2	Neutral	CB 1	CB 2	Neutral	CB 1	CB 2	Neutral	CB 1	CB 2	Neutral							
09T302										●				d	d1	s	l	r	PDC l1	TFC l1
09T304				●			●			●				9,52	4,4	3,97	9,52	0,2		3,0
09T308							●			●			○					0,4	4,4	2,8
09T312							●						○					0,8	4,3	2,6
120404				●			●							12,70	5,5	4,76	12,70	1,2	4,2	2,3
120408							●						○					0,4	4,4	
120412							●						○					0,8	4,3	2,6
																		1,2	4,2	2,3



TURNING | ISO

■ SCGW

neutral, whole edge

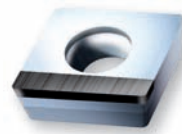

insert size	PDC-CU-S			PDC-S			PDC			TFC			MDC	dimensions					
	Neutral	CB 1	CB 2	Neutral	CB 1	CB 2	Neutral	CB 1	CB 2	Neutral	CB 1	CB 2	Neutral						
														d	d ₁	s	l	r	l ₁
09T304-GS							●							9,52	4,4	3,97		0,4	9,52
09T308-GS							●											0,8	9,52
120404-GS							●											0,4	12,70
120408-GS							●							12,70	5,5	4,76		0,8	12,70
120412-GS							●											1,2	12,70

■ SNGA

neutral

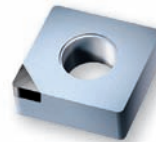

insert size	PDC-CU-S			PDC-S			PDC			TFC			MDC	dimensions					
	Neutral	CB 1	CB 2	Neutral	CB 1	CB 2	Neutral	CB 1	CB 2	Neutral	CB 1	CB 2	Neutral						
														d	d ₁	s	l	r	l ₁
120404				●			●											0,4	4,3
120408				●			●							12,70	5,13	4,76		0,8	4,2
120412				●			●											1,2	4,0

■ SPGN

neutral

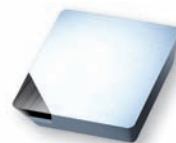

insert size	PDC-CU-S			PDC-S			PDC			TFC			MDC	dimensions					
	Neutral	CB 1	CB 2	Neutral	CB 1	CB 2	Neutral	CB 1	CB 2	Neutral	CB 1	CB 2	Neutral						
														d	d ₁	s	l	r	l ₁
120304				●			●											0,4	4,4
120308							●						○	12,70		3,18	12,7	0,8	4,3

SPGT

positive neutral

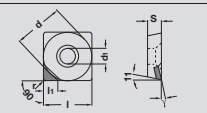

insert size	PDC-CU-S			PDC-S			PDC			TFC			MDC	dimensions					
	Neutral	CB 1	CB 2	Neutral	CB 1	CB 2	Neutral	CB 1	CB 2	Neutral	CB 1	CB 2	Neutral						
09T304				●										d	d ₁	s	l	r	l ₁
09T308				●										9,52	4,4	3,97	9,5	0,4	4,4
09T312				●														0,8	4,3
																		1,2	4,2

SPGT

positive, whole edge

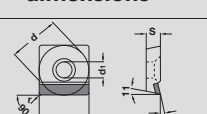

insert size	PDC-CU-S			PDC-S			PDC			TFC			MDC	dimensions					
	Neutral	CB 1	CB 2	Neutral	CB 1	CB 2	Neutral	CB 1	CB 2	Neutral	CB 1	CB 2	Neutral						
09T308-GS				●										d	d ₁	s	l	r	l ₁
09T312-GS				●										9,52	4,4	3,97		0,8	9,52
																		1,2	

SPGW

neutral



insert size	PDC-CU-S			PDC-S			PDC			TFC			MDC	dimensions						
	Neutral	CB 1	CB 2	Neutral	CB 1	CB 2	Neutral	CB 1	CB 2	Neutral	CB 1	CB 2	Neutral	d	d ₁	s	l	r	PDC l ₁	MDC l ₁
09T304							●											0,4	4,4	
09T308							●						○	9,52	4,4	3,97	9,52	0,8	4,3	2,6
09T312							●											1,2	4,2	



TURNING | ISO

TCGT

positive neutral



insert size	PDC-CU-S			PDC-S			PDC			TFC			MDC	dimensions						
	Neutral	CB 1	CB 2	Neutral	CB 1	CB 2	Neutral	CB 1	CB 2	Neutral	CB 1	CB 2	Neutral							
														d	d ₁	s	l	r	PDC l ₁	TFC l ₁
090202				●		●	●	●			●	●						0,2	3,7	2,6
090204				●		●	●	●			●	●		5,56	2,5	2,38	9,6	0,4	3,4	2,3
090208							●											0,8	3,0	2,0
110202				●		●	●	●			●	●						0,2	3,7	2,6
110204				●		●	●	●			●	●		6,35	2,8	2,38	11,0	0,4	3,4	2,3
110208							●											0,8	3,0	2,0
16T304				●		●	●	●			●	●		9,52	4,4	3,97	16,5	0,4	4,6	2,3
16T308						●	●	●			●	●						0,8	4,2	2,0

TCGT

positive, whole edge

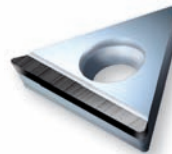

insert size	PDC-CU-S			PDC-S			PDC			TFC			MDC	dimensions						
	Neutral	CB 1	CB 2	Neutral	CB 1	CB 2	Neutral	CB 1	CB 2	Neutral	CB 1	CB 2	Neutral							
														d	d ₁	s	l	r	l ₁	
090204-GS				●														0,4	9,6	
090208-GS				●										5,56	2,5	2,38		0,8		
110204-GS				●														0,4	11,0	
110208-GS				●										6,35	2,8	2,38		0,8		
110212-GS				●														1,2		
16T304-GS				●										9,52	4,4	3,97		0,4	16,5	
16T308-GS				●														0,8		



TCGW neutral

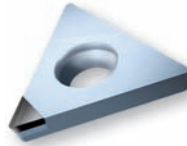

insert size	PDC-CU-S			PDC-S			PDC			TFC			MDC	dimensions								
	Neutral	CB 1	CB 2	Neutral	CB 1	CB 2	Neutral	CB 1	CB 2	Neutral	CB 1	CB 2	Neutral									
														d	d ₁	s	l	r	PDC		TFC	
090202				●			●						○						0,2	3,7	2,6	
090204				●			●						●	5,56	2,5	2,38	9,6		0,4	3,4	2,3	
090208							●						○						0,8	3,0	2,0	
110202				●			●			●			○						0,2	3,7	2,6	
110204	●			●			●			●			●	6,35	2,8	2,38	11,0		0,4	3,4	2,3	
110208	●						●			●			●						0,8	3,0	2,0	
16T304	●						●			●			○						0,4	4,6	2,3	
16T308	●						●			●			○	9,52	4,4	3,97	16,5		0,8	4,2	2,0	
16T312							●						○						1,2	3,8	1,8	

TCGW neutral, whole edge

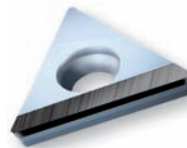

insert size	PDC-CU-S			PDC-S			PDC			TFC			MDC	dimensions						
	Neutral	CB 1	CB 2	Neutral	CB 1	CB 2	Neutral	CB 1	CB 2	Neutral	CB 1	CB 2	Neutral							
														d	d ₁	s	l	r	l ₁	
090208-GS							●							5,56	2,5	2,38		0,8	9,6	
110204-GS	●						●							6,35	2,8	2,38		0,4	11,0	
110208-GS							●											0,8		
16T304-GS							●							9,52	4,4	3,97		0,4	16,5	
16T308-GS							●											0,8		

TCGW fullface

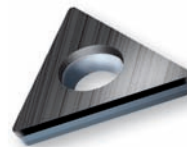

insert size	PDC-CU-S			PDC-S			PDC			TFC			MDC	dimensions							
	Neutral	CB 1	CB 2	Neutral	CB 1	CB 2	Neutral	CB 1	CB 2	Neutral	CB 1	CB 2	Neutral								
														d	d ₁	s	l	r	l ₁		
110202-VM							●												0,2		
110204-VM							●							6,35	2,8	2,38		0,4	11,0		
110208-VM							●											0,8			



TURNING | ISO

■ TNGA neutral



insert size	PDC-CU-S			PDC-S			PDC			TFC			MDC	dimensions					
	Neutral	CB 1	CB 2	Neutral	CB 1	CB 2	Neutral	CB 1	CB 2	Neutral	CB 1	CB 2	Neutral						
														d	d ₁	s	l	r	l ₁
160404	●			●			●											0,4	6,2
160408	●			●			●							9,52	3,81	4,76	16,5	0,8	5,8
160412				●			●											1,2	5,4

■ TPGN neutral

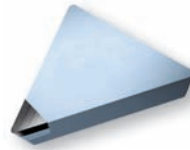

insert size	PDC-CU-S			PDC-S			PDC			TFC			MDC	dimensions						
	Neutral	CB 1	CB 2	Neutral	CB 1	CB 2	Neutral	CB 1	CB 2	Neutral	CB 1	CB 2	Neutral							
														d	d ₁	s	l	r	PDC l ₁	MDC l ₁
110302				●			●											0,2	3,7	2,6
110304				●			●						○	6,35		3,18	11,0	0,4	3,4	2,3
110308							●						○					0,8	3,0	2,0
160304				●			●											0,4	4,6	
160308				●			●						○	9,52		3,18	16,5	0,8	4,2	
160312							●											1,2	3,8	

TPGN

neutral, whole edge

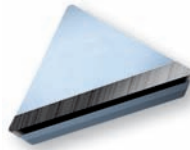

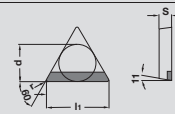
insert size	PDC-CU-S			PDC-S			PDC			TFC			MDC	dimensions					
	Neutral	CB 1	CB 2	Neutral	CB 1	CB 2	Neutral	CB 1	CB 2	Neutral	CB 1	CB 2	Neutral						
														d	d ₁	s	l	r	l ₁
110304-GS							●							6,35		3,18		0,4	11,0
110308-GS							●										0,8		
160304-GS							●							9,52		3,18		0,4	16,5
160308-GS							●										0,8		

TPGW

neutral, whole edge

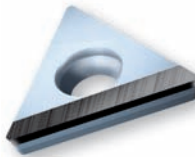

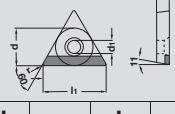
insert size	PDC-CU-S			PDC-S			PDC			TFC			MDC	dimensions					
	Neutral	CB 1	CB 2	Neutral	CB 1	CB 2	Neutral	CB 1	CB 2	Neutral	CB 1	CB 2	Neutral						
														d	d ₁	s	l	r	l ₁
080204-GS							●							4,76	2,2	2,38		0,4	8,2
090204-GS							●							5,56	2,5	2,38		0,4	9,6
110204-GS							●							6,35	2,8	2,38		0,4	11,0
110304-GS							●									3,18		0,4	11,0



TURNING | ISO

TPGW neutral

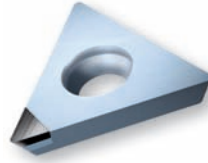

insert size	PDC-CU-S			PDC-S			PDC			TFC			MDC	dimensions					
	Neutral	CB 1	CB 2	Neutral	CB 1	CB 2	Neutral	CB 1	CB 2	Neutral	CB 1	CB 2	Neutral						
														d	d ₁	s	r	l	PDC l ₁
080204							●							4,76	2,8	2,38	0,4	8,2	2,7
090202							●							5,56	2,5	2,38	0,2	9,6	3,7
090204							●						0,4				3,4		
090208							●						0,8				3,0		
110202							●						0,2				3,7		
110204							●						6,35	2,8	2,38	0,4	11,0	3,4	
110208							●									0,8		3,0	
110302							●									0,4		3,7	
110304							●						6,35	2,5	3,18	0,8	11,0	3,4	
110308							●									1,2		3,0	

VBGT positive neutral



insert size	PDC-CU-S			PDC-S			PDC			TFC			MDC	dimensions						
	Neutral	CB 1	CB 2	Neutral	CB 1	CB 2	Neutral	CB 1	CB 2	Neutral	CB 1	CB 2	Neutral							
														d	d ₁	s	l	r	PDC l ₁	TFC l ₁
110201				●										6,35	2,8	2,38	11,1	0,1	5,4	
110202				●			●											0,2	4,6	
110204				●			●											0,4	3,9	
110208				●			●											0,8	3,3	
160402		●		●		●	●	●			●	●		9,52	4,4	4,76	16,6	0,2	5,9	3,0
160404			●	●	●	●	●	●			●	●	○					0,4	5,5	3,0
160408			●	●	●	●	●	●			●	●						0,8	5,0	3,0
160412				●	●	●	●	●			●	●						1,2	4,4	3,0



VBGW neutral

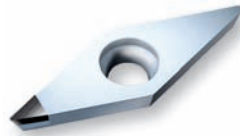

insert size	PDC-CU-S			PDC-S			PDC			TFC			MDC	dimensions						
	Neutral	CB 1	CB 2	Neutral	CB 1	CB 2	Neutral	CB 1	CB 2	Neutral	CB 1	CB 2	Neutral							
														d	d ₁	s	l	r	PDC l ₁	TFC l ₁
110202							●											0,2	4,6	
110204							●						○	6,35	2,8	2,38	11,1	0,4	3,9	
110208							●											0,8	3,3	
160402	●						●			●								0,2	5,9	3,0
160404	●						●			●			○	9,52	4,4	4,76	16,6	0,4	5,5	3,0
160408	●						●			●								0,8	5,0	3,0
160412							●											1,2	4,4	

VCGT positive neutral



insert size	PDC-CU-S			PDC-S			PDC			TFC			MDC	dimensions						
	Neutral	CB 1	CB 2	Neutral	CB 1	CB 2	Neutral	CB 1	CB 2	Neutral	CB 1	CB 2	Neutral							
														d	d ₁	s	l	r	PDC l ₁	TFC l ₁
070201				●														0,1	3,8	
070202				●			●						○	3,97	2,2	2,38	6,9	0,2	3,6	3,0
070204				●			●											0,4	3,2	2,8
110301				●			●	●			●							0,1	5,4	
110302			●	●	●	●	●	●			●	●	○	6,35	2,8	3,18	11,1	0,2	4,6	3,5
110304			●	●	●	●	●	●			●	●	○					0,4	3,9	3,0
110308				●	●	●	●	●			●	●	○					0,8	3,3	3,0
130302				●			●											0,2	5,9	
130304				●			●							7,94	3,4	3,18	13,3	0,4	5,5	
160401				●			●											0,1	6,0	
160402			●	●		●	●	●			●	●	○					0,2	5,9	3,5
160404	●		●	●	●	●	●	●			●	●	○	9,52	4,4	4,76	16,6	0,4	5,5	3,0
160408				●	●	●	●	●			●	●	○					0,8	5,0	3,0
160412				●	●		●	●			●	●						1,2	4,5	3,0



TURNING | ISO

■ VCGT

positive, right or left hand

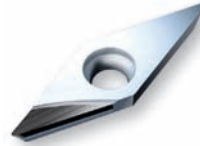

insert size	PDC-CU-S			PDC-S			PDC			TFC			MDC	dimensions								
	Neutral	CB 1	CB 2	Neutral	CB 1	CB 2	Neutral	CB 1	CB 2	Neutral	CB 1	CB 2	Neutral									
														d	d ₁	s	l	r	l ₁			
110304R/L							●							6,35	2,8	3,18	11,1	0,4	6,5			
110308R/L							●											0,8	6,0			
160404R/L							●											0,4	7,5			
160408R/L							●							9,52	4,4	4,76	16,6	0,8	7,0			
160412R/L							●											1,2	7,0			

■ VCGW

neutral

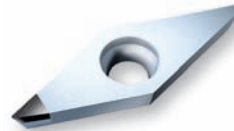

insert size	PDC-CU-S			PDC-S			PDC			TFC			MDC	dimensions									
	Neutral	CB 1	CB 2	Neutral	CB 1	CB 2	Neutral	CB 1	CB 2	Neutral	CB 1	CB 2	Neutral										
														d	d ₁	s	l	r	PDC l ₁	TFC l ₁			
070201				●														0,1	3,8				
070202				●			●							3,97	2,2	2,38	6,9	0,2	3,6	3,0			
070204				●			●											0,4	3,2	2,8			
110301				●														0,1	5,4				
110302	●			●			●			●			○	6,35	2,8	3,18	11,1	0,2	4,6	3,5			
110304	●			●			●			●			○					0,4	3,9	3,0			
110308							●			●			○					0,8	3,3	3,0			
130302				●			●											0,2	5,9				
130304							●							7,94	3,4	3,18	13,3	0,4	5,5				
160401				●														0,1	6,0				
160402	●			●			●			●			○					0,2	5,9	3,5			
160404	●			●			●			●			○	9,52	4,4	4,76	16,6	0,4	5,5	3,0			
160408				●			●			●			○					0,8	5,0	3,0			
160412				●			●						○					1,2	4,5	3,0			

VNMA

neutral

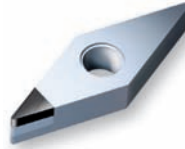

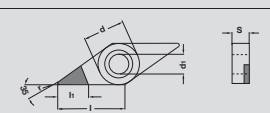
insert size	PDC-CU-S			PDC-S			PDC			TFC			MDC	dimensions						
	Neutral	CB 1	CB 2	Neutral	CB 1	CB 2	Neutral	CB 1	CB 2	Neutral	CB 1	CB 2	Neutral							
														d	d ₁	s	l	r	l ₁	
160404				●			●												0,4	5,5
160408	●			●			●							9,52	3,81	4,76	16,6		0,8	5,0
160412				●			●												1,2	4,5

WBGW

fullface

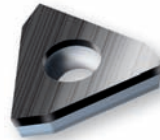

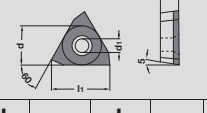
insert size	PDC-CU-S			PDC-S			PDC			TFC			MDC	dimensions						
	Neutral	CB 1	CB 2	Neutral	CB 1	CB 2	Neutral	CB 1	CB 2	Neutral	CB 1	CB 2	Neutral							
														d	d ₁	s	l	r	l ₁	
020102L-VM							●												0,2	4,8
020104L-VM							●							3,97	2,3	1,58			0,4	

WCGW

fullface

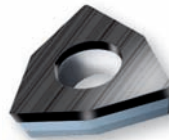

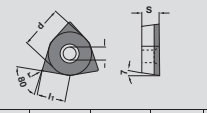
insert size	PDC-CU-S			PDC-S			PDC			TFC			MDC	dimensions						
	Neutral	CB 1	CB 2	Neutral	CB 1	CB 2	Neutral	CB 1	CB 2	Neutral	CB 1	CB 2	Neutral							
														d	d ₁	s	l	r	l ₁	
020102-VM	●						●												0,2	2,7
020104-VM	●						●							3,97	2,3	1,58			0,4	



GROOVING FormCut

TECHNOLOGY

TURNING

GROOVING

BORING

MILLING

BSAFR/L

Toolholder, external radial grooving



right hand shown

Note: For right-hand toolholders use right-hand inserts, for left-hand toolholders use left-hand inserts only.



designation		dimensions					
right-hand	left-hand	h_1	h_2	b	f	L_1	L_2
BSAFR 1616 - 12	BSAFL 1616 - 12	16	16	16	20	106	31
BSAFR 2020 - 12	BSAFL 2020 - 12	20	20	20	24	131	31
BSAFR 2525 - 12	BSAFL 2525 - 12	25	25	25	30	156	31
BSAFR 3225 - 12	BSAFL 3225 - 12	32	32	25	30	176	31

BSIFR/L

Toolholder, internal radial grooving

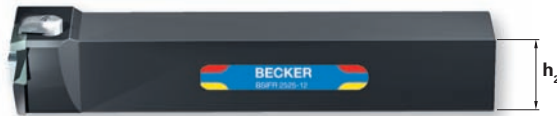

right hand shown

Note: For right-hand toolholders use left-hand inserts, for left-hand toolholders use right-hand inserts only.

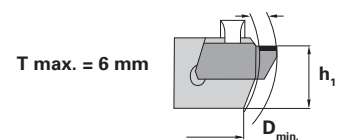
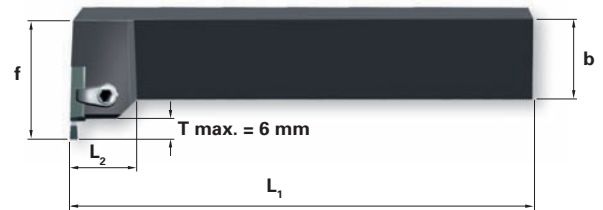

designation		dimensions						
right-hand	left-hand	h_1	h_2	b	f	L_1	L_2	$D_{min.}$
BSIFR 1616 - 12	BSIFL 1616 - 12	16	16	16	28	100	18	50
BSIFR 2020 - 12	BSIFL 2020 - 12	20	20	20	32	125	18	72
BSIFR 2525 - 12	BSIFL 2525 - 12	25	25	25	37	150	18	110
BSIFR 3225 - 12	BSIFL 3225 - 12	32	32	25	37	170	18	110

Spare parts



BFSN-R/L

External grooving

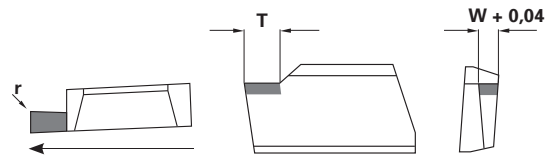
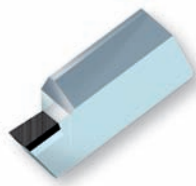

right hand shown

insert size	PDC-CU-S			PDC-S			PDC			TFC			MDC	dimensions			
	Neutral	CB 1	CB 2	Neutral	CB 1	CB 2	Neutral	CB 1	CB 2	Neutral	CB 1	CB 2	Neutral				
	W	T	r	r													
BFSN-2,5-R/L							●			●	○			2,5	4	0,2	
BFSN-3,0-R/L			●				●			●	○			3,0	6	0,2	0,4
BFSN-3,5-R/L			●				●			●	○			3,5	6	0,2	
BFSN-4,0-R/L			●				●			●	○			4,0	6	0,2	0,4
BFSN-4,5-R/L							●			○				4,5	6	0,2	
BFSN-5,0-R/L							●			○				5,0	6	0,2	0,4

BFSV-R/L

External grooving and turning

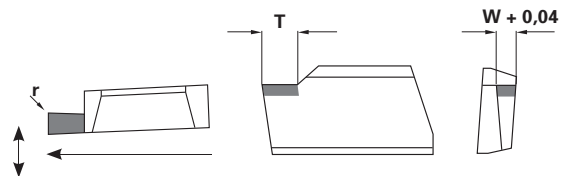

right hand shown

insert size	PDC-CU-S			PDC-S			PDC			TFC			MDC	dimensions			
	Neutral	CB 1	CB 2	Neutral	CB 1	CB 2	Neutral	CB 1	CB 2	Neutral	CB 1	CB 2	Neutral				
	W	T	r	r													
BFSV-3,0-R/L			●				●			●	○			3,0	6	0,2	0,4
BFSV-3,5-R/L			●				●			●	○			3,5	6	0,2	0,4
BFSV-4,0-R/L			●				●			●	○			4,0	6	0,2	0,5
BFSV-4,5-R/L			●				●			○				4,5	6	0,2	0,5
BFSV-5,0-R/L			●				●			○				5,0	6	0,2	0,6



GROOVING | FormCut

TECHNOLOGY

TURNING

GROOVING

BORING

MILLING

■ BFIN-R/L

Internal grooving

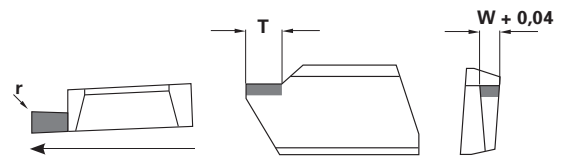
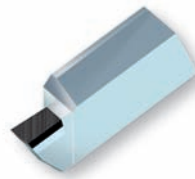

right hand shown

insert size	PDC-CU-S			PDC-S			PDC			TFC			MDC	dimensions			
	Neutral	CB 1	CB 2	Neutral	CB 1	CB 2	Neutral	CB 1	CB 2	Neutral	CB 1	CB 2	Neutral	W	T	r	r
BFIN-2,5-R/L							●							2,5	4	0,2	
BFIN-3,0-R/L							●							3,0	6	0,2	0,4
BFIN-3,5-R/L							●							3,5	6	0,2	
BFIN-4,0-R/L							●							4,0	6	0,2	0,4
BFIN-4,5-R/L							●							4,5	6	0,2	
BFIN-5,0-R/L							●							5,0	6	0,2	0,4

■ BFIV-R/L

Internal grooving and turning

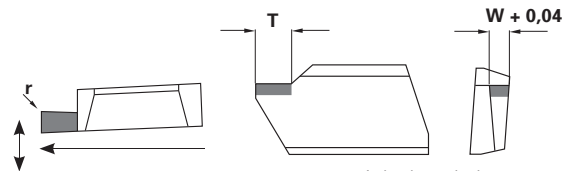

right hand shown

insert size	PDC-CU-S			PDC-S			PDC			TFC			MDC	dimensions			
	Neutral	CB 1	CB 2	Neutral	CB 1	CB 2	Neutral	CB 1	CB 2	Neutral	CB 1	CB 2	Neutral	W	T	r	r
BFIV-3,0-R/L							●							3,0	6	0,2	0,4
BFIV-3,5-R/L							●							3,5	6	0,2	0,4
BFIV-4,0-R/L							●							4,0	6	0,2	0,4
BFIV-4,5-R/L							●							4,5	6	0,2	0,4
BFIV-5,0-R/L							●							5,0	6	0,2	0,4

■ BFRV-R/L

External copying

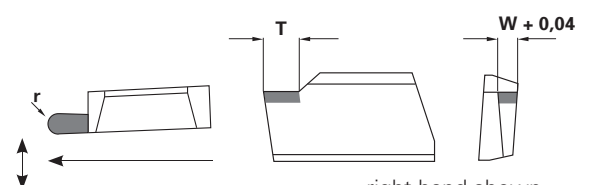

right hand shown

insert size	PDC-CU-S			PDC-S			PDC			TFC			MDC	dimensions		
	Neutral	CB 1	CB 2	Neutral	CB 1	CB 2	Neutral	CB 1	CB 2	Neutral	CB 1	CB 2	Neutral	W	T	r
BFRV-3,0-R/L			●				●			●	○			3,0	6	1,50
BFRV-3,5-R/L			●				●			●	○			3,5	6	1,75
BFRV-4,0-R/L			●				●			●	○			4,0	6	2,00
BFRV-4,5-R/L			●				●			●	○			4,5	6	2,25
BFRV-5,0-R/L			●				●			●	○			5,0	6	2,50

■ BFDV-R/L

External profiling

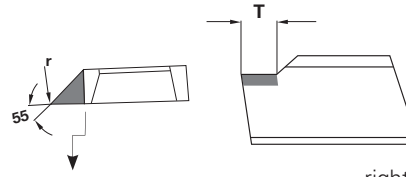
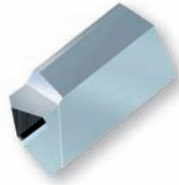

right hand shown

insert size	PDC-CU-S			PDC-S			PDC			TFC			MDC	dimensions			
	Neutral	CB 1	CB 2	Neutral	CB 1	CB 2	Neutral	CB 1	CB 2	Neutral	CB 1	CB 2	Neutral				
BFDV-0,2-R/L							●								W	T	r
BFDV-0,4-R/L							●								5	5	0,2
BFDV-0,8-R/L							●								5	5	0,4
BFDV-1,2-R/L							●								5	5	0,8
															5	5	1,2

■ BFTV-R/L

External threading
(partial profile)

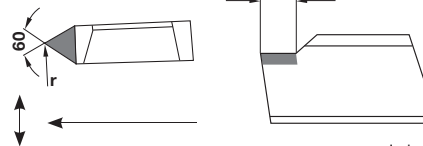
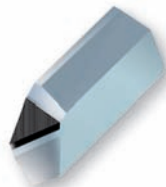

right hand shown

insert size	PDC-CU-S			PDC-S			PDC			TFC			MDC	dimensions			
	Neutral	CB 1	CB 2	Neutral	CB 1	CB 2	Neutral	CB 1	CB 2	Neutral	CB 1	CB 2	Neutral				
BFTV-0,10-R/L							●			●					W	T	r
BFTV-0,14-R/L							●			●					5	5	0,10
BFTV-0,18-R/L							●			●					5	5	0,14
BFTV-0,21-R/L							●			●					5	5	0,18
BFTV-0,25-R/L							●			●					5	5	0,21
BFTV-0,28-R/L							●			●					5	5	0,25
BFTV-0,36-R/L							●			●					5	5	0,28
BFTV-0,43-R/L							●			●					5	5	0,36
															5	5	0,43

Size of radius for metric ISO-thread.

Size of radius	Pitch P (max.)	Pitch P (min.)	Pitch P (average)
r = 0,10	P = 0,80	P = 0,69	P = 0,75
r = 0,14	P = 1,12	P = 0,97	P = 1,00
r = 0,18	P = 1,44	P = 1,25	P = 1,35
r = 0,21	P = 1,68	P = 1,46	P = 1,55
r = 0,25	P = 2,00	P = 1,74	P = 1,87
r = 0,28	P = 2,24	P = 1,95	P = 2,10
r = 0,36	P = 2,99	P = 2,50	P = 2,70
r = 0,43	P = 3,44	P = 2,99	P = 3,20

Boring bars solid carbide

Design E...SEUP L/R

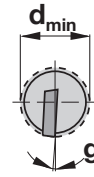
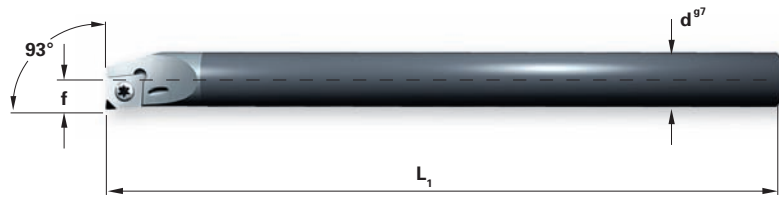

right hand shown

Right-hand boring bar with cylindrical solid carbide shank and internal coolant feed.

order number	insert	dimensions				
		d_{min}	d^{97}	f	L_1	g
E 06 F - SEUP L/R 04	EPH.. 0401..	6,8	6	3,4	80	9°
E 07 H - SEUP L/R 04	EPH.. 0401..	8,4	7	4,4	100	5°
E 08 H - SEUP L/R 04	EPH.. 0401..	9,5	8	4,9	100	5°
E 10 K - SEUP L/R 06	EPH.. 06T1..	11,5	10	5,8	125	5°
E 12 M - SEUP L/R 06	EPH.. 06T1..	13,5	12	6,9	150	3°
E 16 R - SEUP L/R 06	EPH.. 06T1..	18,5	16	9,8	200	0°

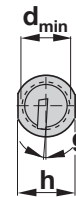
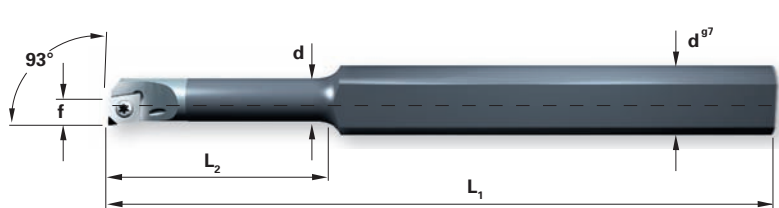

right hand shown

Right-hand boring bar with cylindrical solid carbide shank, two clamping surfaces and internal coolant feed.

order number	insert	dimensions							
		d_{min}	d	f	L_1	L_2	d^{97}	h	g
E 06 10 H - SEUP L/R 04	EPH.. 0401..	6,8	6	3,4	100	36	10	8	9°
E 07 10 K - SEUP L/R 04	EPH.. 0401..	8,4	7	4,4	125	42	10	8	5°
E 08 10 K - SEUP L/R 04	EPH.. 0401..	9,5	8	4,9	125	48	10	8	5°

Spare parts

screws and keys					
order number	SCR 1101	SCR 1102	KEY 2101	KEY 2102	VAR 5101
suitable for	EPH 0401..	EPH 06T1..	SCR 1101	SCR 1102	



EPHT EPHW



insert size	PDC-CU-S			PDC-S			PDC			TFC			MDC	dimensions					
	Neutral	CB 1	CB 2	Neutral	CB 1	CB 2	Neutral	CB 1	CB 2	Neutral	CB 1	CB 2	Neutral						
														d	d ₁	s	l	r	l ₁
EPHT040101-VM						●	●	●										0,1	4,9
EPHT040102-VM						●	●	●						4,76	2,2	1,58	4,9	0,2	4,8
EPHT040104-VM						●	●	●										0,4	4,7
EPHW040102-VM				●			●											0,1	4,9
EPHW040103-VM				●			●							4,76	2,2	1,58	4,9	0,3	4,8
EPHW040104-VM				●			●											0,4	4,7

EPHT EPHW



insert size	PDC-CU-S			PDC-S			PDC			TFC			MDC	dimensions					
	Neutral	CB 1	CB 2	Neutral	CB 1	CB 2	Neutral	CB 1	CB 2	Neutral	CB 1	CB 2	Neutral						
														d	d ₁	s	l	r	l ₁
EPHT06T101				●			●											0,1	3,1
EPHT06T102				●		●	●	●			●	●		6,35	2,8	1,98	6,6	0,2	3,0
EPHT06T104				●		●	●	●			●	●						0,4	2,8
EPHW06T101				●			●											0,1	3,1
EPHW06T102				●			●							6,35	2,8	1,98	6,6	0,2	3,0
EPHW06T104				●			●											0,4	2,8

Contra to most conventional tool systems we use positive indexable insert types EPHW / EPHT 0401.. and 06T1.. with a 75 style. This established insert type make us achieve best-possible performance for boring. Our solid carbide boring bars allow for a boring depth of 7xD with the highest precision and surface finish.

■ Adapter sleeve

Boring Bars Design X...GEUP

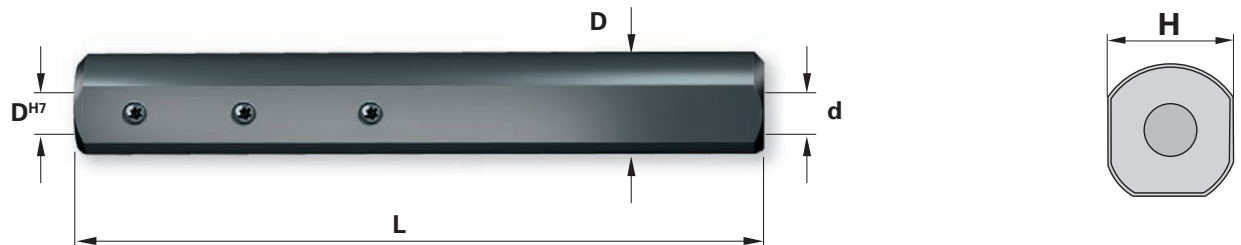

Adapter sleeves enable versatile use of the boring bars in all areas.
Coolant feed is provided through the adapter.

order number	for boring bars	dimensions				
		D	d	d ^{H7}	H	L
Adap - 1635	X 3,5 F-GEUP L/R	16	4	3,5	14	100
Adap - 1640	X 04 F-GEUP L/R	16	5	4,0	14	100
Adap - 1650	X 06 H-GEUP L/R	16	6	5,0	14	100
Adap - 1660	X 05 H-GEUP L/R	16	8	6,0	14	100

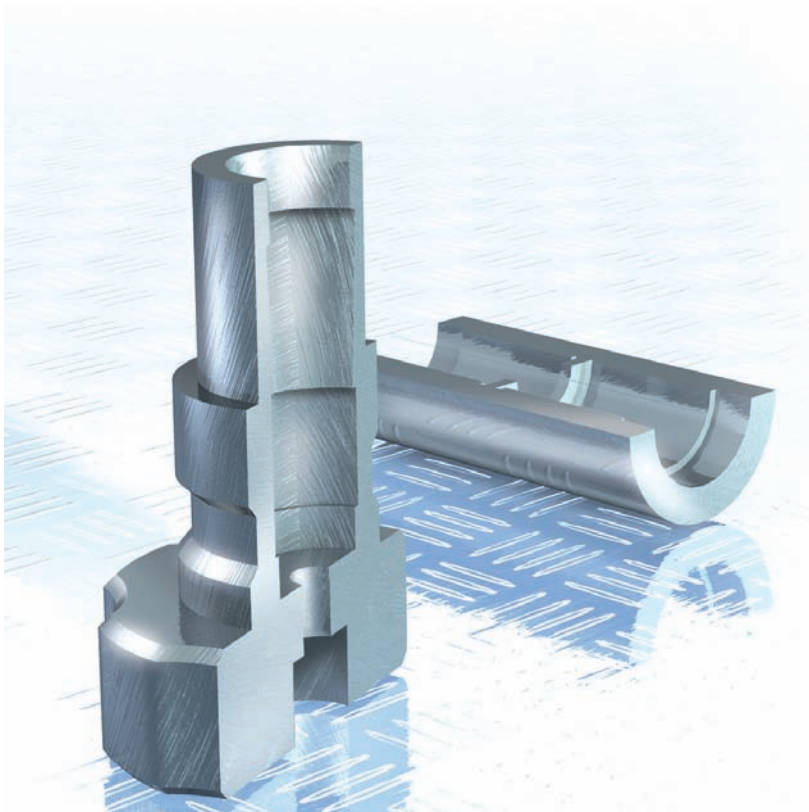

X-GE R/L

Solide carbide boring bars with one clamping surface, brazed cutting edges and internal coolant feed. Adapter Sleeve look left.

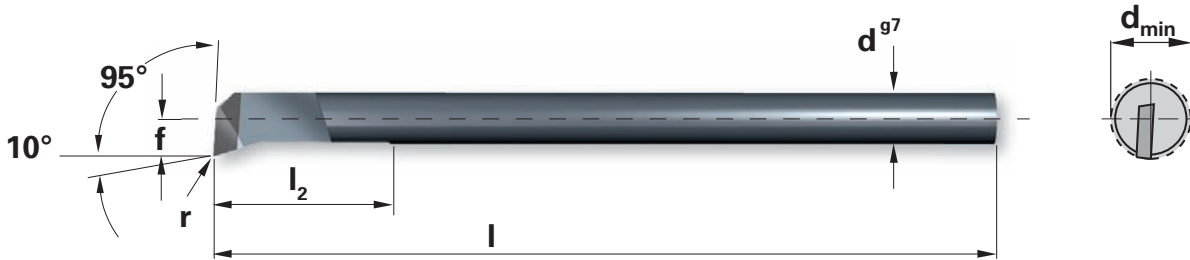

right hand shown

order number	PDC-CU-S			PDC-S			PDC			TFC			MDC	dimensions					
	Neutral	CB 1	CB 2	Neutral	CB 1	CB 2	Neutral	CB 1	CB 2	Neutral	CB 1	CB 2	Neutral	dg ₇	d _{min}	f	l ₁	l ₂	r
	X3,5F-GEUP-R/L				●										3,5	4,0	2,0	80	12
X3,5F-GEUP-R/L				●															0,2
X04F-GEUP-R/L				●															0,1
X04F-GEUP-R/L				●										4,0	5,0	2,5	80	14	0,2
X04F-GEUP-R/L				●															0,4
X05H-GEUP-R/L				●															0,1
X05H-GEUP-R/L				●										5,0	6,0	3,0	100	18	0,2
X05H-GEUP-R/L				●															0,4
X06H-GEUP- R/L				●															0,1
X06H-GEUP- R/L				●										6,0	7,0	3,5	100	20	0,2
X06H-GEUP- R/L				●															0,4

All tipped MiniCut-boring bars consist of solid carbide with integrated coolant feed and allow for boring depth up to 7xD. Like our MiniCut-inserts, the boring bars are designed in 75 style and ensure highest performance.



MILLING | ISO

TECHNOLOGY

TURNING

GROOVING

BORING

MILLING

CPGW-PDR

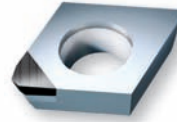

insert size	PDC-CU-S			PDC-S			PDC			TFC			MDC	dimensions				
	Neutral	CB 1	CB 2	Neutral	CB 1	CB 2	Neutral	CB 1	CB 2	Neutral	CB 1	CB 2	Neutral	d	d ₁	s	l	l ₁
1204-PDR-4				●										12,7	5,5	4,76	12,7	4,5
1204-PDR-6				●														7,5

RDHX

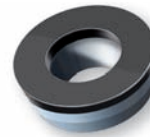

insert size	PDC-CU-S			PDC-S			PDC			TFC			MDC	dimensions				
	Neutral	CB 1	CB 2	Neutral	CB 1	CB 2	Neutral	CB 1	CB 2	Neutral	CB 1	CB 2	Neutral	d	d ₁	s	l	l ₁
0501M0				●										5,0	2,0	1,50		
0702M0				●										7,0	2,7	2,38		
1003M0				●										10,0	3,8	3,18		
12T3M0				●										12,0	3,8	3,97		

SDHW-AEN

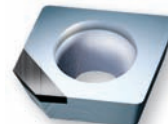

insert size	PDC-CU-S			PDC-S			PDC			TFC			MDC	dimensions				
	Neutral	CB 1	CB 2	Neutral	CB 1	CB 2	Neutral	CB 1	CB 2	Neutral	CB 1	CB 2	Neutral	d	d ₁	s	l	l ₁
1204AEN-4				●										12,7	5,5	4,76	12,7	4,0
1204AEN-6				●														6,0

SEHW-AFN

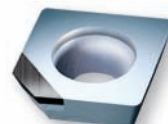

insert size	PDC-CU-S			PDC-S			PDC			TFC			MDC	dimensions				
	Neutral	CB 1	CB 2	Neutral	CB 1	CB 2	Neutral	CB 1	CB 2	Neutral	CB 1	CB 2	Neutral	d	d ₁	s	l	l ₁
1204-AFN-4				●										12,7	5,5	4,76	12,7	4,0

SEKN-AFN

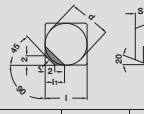

insert size	PDC-CU-S			PDC-S			PDC			TFC			MDC	dimensions				
	Neutral	CB 1	CB 2	Neutral	CB 1	CB 2	Neutral	CB 1	CB 2	Neutral	CB 1	CB 2	Neutral					
														d	d ₁	s	l	l ₁
1203AFN-4				●										12,7		3,18	12,7	4,0
1203AFN-6				●														6,0

SPGW-PDR

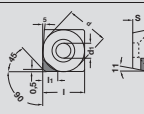

insert size	PDC-CU-S			PDC-S			PDC			TFC			MDC	dimensions				
	Neutral	CB 1	CB 2	Neutral	CB 1	CB 2	Neutral	CB 1	CB 2	Neutral	CB 1	CB 2	Neutral					
														d	d ₁	s	l	l ₁
1204PDR-4				●										12,7	5,5	4,76	12,7	4,0

TPKN-PDR

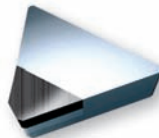

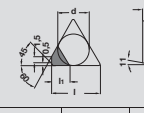
insert size	PDC-CU-S			PDC-S			PDC			TFC			MDC	dimensions				
	Neutral	CB 1	CB 2	Neutral	CB 1	CB 2	Neutral	CB 1	CB 2	Neutral	CB 1	CB 2	Neutral					
														d	d ₁	s	l	l ₁
1603PDR-4				●										9,52		3,18	16,5	4,0

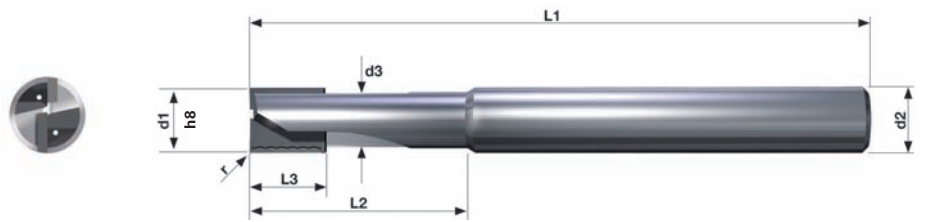

■ BMC-S

Two Flutes End Mill
with Through Coolant

article	TFC											
	Neutral	CB 1	CB 2	dimensions								
				d_1/h_8	r	d_2	d_3	z	axial angle	L_1	L_2	L_3
BMC-S04-85	●	○	○	4	0,1	6	3,5	2	+2°	50	10	5,0
BMC-S05-85	●	○	○	5	0,1	6	4,3	2	+2°	50	12	6,0
BMC-S06-85	●	○	○	6	0,2	6	5,1	2	+2°	57	15	8,0
BMC-S08-85	●	○	○	8	0,2	8	6,9	2	+2°	63	20	10,0
BMC-S10-85	●	○	○	10	0,2	10	8,5	2	+2°	72	26	12,0
BMC-S12-85	●	○	○	12	0,2	12	10,1	3	+2°	83	32	15,0
BMC-S04-35	●	○	○	4	0,1	6	3,5	2	-2°	50	10	5,0
BMC-S05-35	●	○	○	5	0,1	6	4,3	2	-2°	50	12	6,0
BMC-S06-35	●	○	○	6	0,2	6	5,1	2	-2°	57	15	8,0
BMC-S08-35	●	○	○	8	0,2	8	6,9	2	-2°	63	20	10,0
BMC-S10-35	●	○	○	10	0,2	10	8,5	2	-2°	72	26	12,0
BMC-S12-35	●	○	○	12	0,2	12	10,1	3	-2°	83	32	15,0

Vc: page 11 $f_z = 0,03 - 0,3 \text{ mm/U}$ $a_p = 0,5 - 12 \text{ mm}$

see Information page12

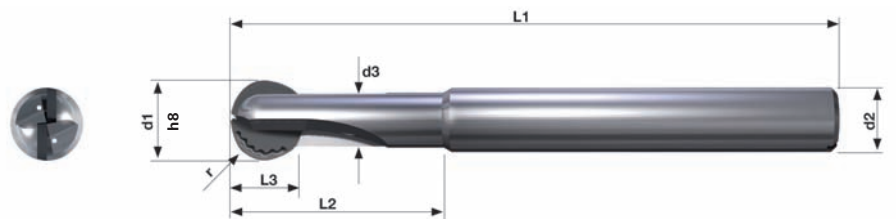

■ BMC-K

Two Flutes Ball End Mill
with Through Coolant

article	TFC											
	Neutral	CB 1	CB 2	dimensions								
				d_1/h_8	r	d_2	d_3	z	axial angle	L_1	L_2	L_3
BMC-K04	●	○	○	4	2-200°	6	3,2	2	0°	60	20	2,5
BMC-K05	●	○	○	5	2,5-200°	6	4,2	2	0°	63	25	3,2
BMC-K06	●	○	○	6	3-210°	6	4,8	2	0°	63	25	3,7
BMC-K08	●	○	○	8	4-220°	8	6,8	2	0°	67	30	5,0
BMC-K10	●	○	○	10	5-220°	10	7,9	2	0°	77	35	6,5
BMC-K12	●	○	○	12	6-220°	12	9,5	2	0°	87	40	7,5

Vc: page 11 $f_z = 0,03 - 0,3 \text{ mm/U}$ $a_p = 0,3 - 6 \text{ mm}$

see Information page12

BMC-T

Two Flutes Torus End Mill with Through Coolant

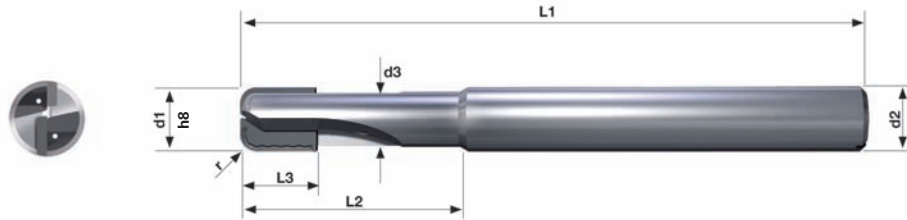

article	TFC			dimensions								
	Neutral	CB 1	CB 2	d_1/h_8	r	d_2	d_3	z	axial angle	L_1	L_2	L_3
BMC-T04 R05	●	○	○	4	0,5	6	3,5	2	0°	50	10	4,0
BMC-T05 R05	●	○	○	5	0,5	6	4,3	2	0°	50	12	4,7
BMC-T05 R10	●	○	○	5	1,0	6	4,3	2	0°	50	12	4,7
BMC-T06 R10	●	○	○	6	1,0	6	5,1	2	0°	57	15	5,2
BMC-T06 R15	●	○	○	6	1,5	6	5,1	2	0°	57	15	5,2
BMC-T08 R10	●	○	○	8	1,0	8	6,9	2	0°	63	20	6,1
BMC-T08 R15	●	○	○	8	1,5	8	6,9	2	0°	63	20	6,1
BMC-T08 R20	●	○	○	8	2,0	8	6,9	2	0°	63	20	6,1
BMC-T10 R10	●	○	○	10	1,0	10	8,5	2	0°	72	26	7,5
BMC-T10 R20	●	○	○	10	2,0	10	8,5	2	0°	72	26	7,5
BMC-T10 R25	●	○	○	10	2,5	10	8,5	2	0°	72	26	7,5
BMC-T12 R10	●	○	○	12	1,0	12	10,1	2	0°	83	32	8,5
BMC-T12 R30	●	○	○	12	3,0	12	10,1	2	0°	83	32	8,5
BMC-T12 R40	●	○	○	12	4,0	12	10,1	2	0°	83	32	8,5

Vc: page 11 $f_z = 0,03 - 0,5 \text{ mm/U}$ $a_p = 0,3 - 7 \text{ mm}$

see Information page 12

BMC-R

Two Flutes Radius End Mill with Through Coolant

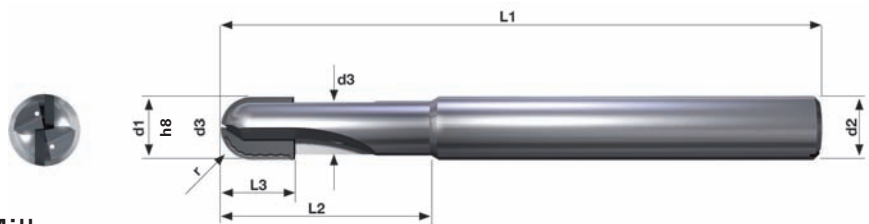

article	TFC			dimensions								
	Neutral	CB 1	CB 2	d_1/h_8	r	d_2	d_3	z	axial angle	L_1	L_2	L_3
BMC-R04	●	○	○	4	2	6	3,5	2	0°	60	20	6,0
BMC-R05	●	○	○	5	2,5	6	4,3	2	0°	63	25	6,0
BMC-R06	●	○	○	6	3	6	5,1	2	0°	63	25	6,0
BMC-R08	●	○	○	8	4	8	6,9	2	0°	67	30	8,0
BMC-R10	●	○	○	10	5	10	8,5	2	0°	77	35	10,0
BMC-R12	●	○	○	12	6	12	10,1	2	0°	87	40	12,0

Vc: page 11 $f_z = 0,03 - 0,35 \text{ mm/U}$ $a_p = 0,2 - 10 \text{ mm}$

see Information page 12



MILLING DiaMill-SPEED

TCP90

Aluminium face milling cutter program engineered for high speed machining of all non-ferrous materials.

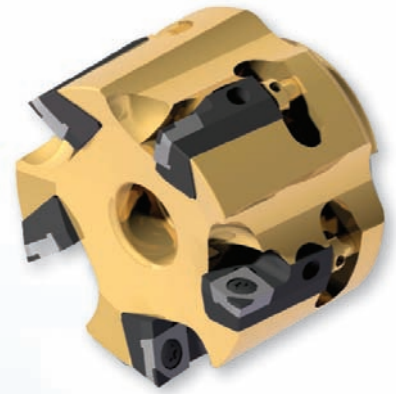
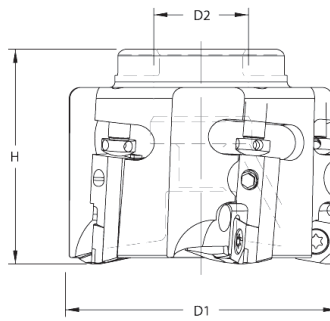

All milling cutters are supplied with factory micro-adjusted cartridges.

order number	D ₁ [mm]	D ₂ [mm]	H [mm]	flutes	n max: Rotation/min	HSC max: m/min	insert
TCP90-50MM-AL	50	22	50	3	27.000	4.239	CPGW-09T304PDR
TCP90-63MM-AL	63	22	50	5	23.000	4.550	
TCP90-80MM-AL	80	27	50	7	18.000	4.522	
TCP90-100MM-AL	100	32	50	10	17.000	5.338	
TCP90-125MM-AL	125	40	50	11	15.000	5.888	
TCP90-160MM-AL	160	40	50	13	12.000	6.029	
TCP90-200MM-AL	200	50	50	16	11.000	6.908	

- Milling cutter bodies made from lightweight 7075-T6 aviation grade aluminium
- Maxicool through coolant enables for maximum chip evacuation and temperature control
- Ultra precise finishing with unique wiper-radius inserts, tipped with TFC-Solid-Diamond and PCD-Cu-S grade and micro adjustable cartridges.

Security Features

Insert Double Lock	Cartridge Dovetail Lock	Enclosed Cartridge Clamping Screw
<p>Secondary insert step locks against matching step on insert cartridge</p> <p>Designed to act as a double lock in conjunction with the insert tapered screw</p>	<p>Insert cartridge is fitted into cutter body with dovetail design</p> <p>Centrifugal forces acting on insert cartridge are neutralized by wedge profile of cartridge and matching shape on cutter body</p>	<p>Unique cartridge shrouds cartridge clamp screw within steel body</p> <p>Potential screw breakage is contained within steel of cartridge – the screw has no place to eject</p>



Performance Features

Micro Adjustable	Through Coolant Enabled	Wiper Radius
<p>Easily pre-set cartridges to within microns</p> <p>All milling cutters are factory pre-set in height to within +/- 0,01 with a master gauge insert</p>	<p>Coolant ports are directed at the cutting edge to external tool life and improve surface finishes</p>	<p>Unique wiper is a compound radius that outperforms traditional wiper flats</p> <p>With every insert in the cutter loaded with the wiper radius, super finishing is easily attained</p>

Accessories

Coolant caps

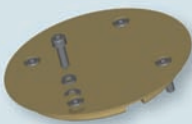
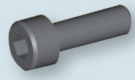
- Optimal coolant caps available for larger cutter diameter to provide 360° direct coolant supply at the cutting edge.
- Balanced by design and mounted securely to maintain constant coolant supply at maximum RPM.
- Made from the same lightweight 7075-T6 aviation grade aluminium as cutter bodies for reliable long term use and service

cutter designation	through coolant cap screw	coolant cap	mounting cap screw	lock washer	washer
					
TCP90-125MM-AL	CCS-125	CTP-125	SHCS-M4	LW-M4	W-M4
TCP90-160MM-AL	CCS-160	CTP-160	SHCS-M5	LW-M5	W-M5
TCP90-200MM-AL	--	CTP-200	SHCS-M8	LW-M8	W-M8

When ordering coolant caps, mounting cap screws and washers are included. Through coolant cap screw must be purchased separately.

Spare parts for DiaMill-SPEED		
Illustr.	Description	Order-No.
M1	Cartridge	CTPC-90
M2	Screw for cartridge	SCR 70
	Torque wrench for cartridge	KEY 520
M3	Insert torx screw (M4)	SCR 90
	Torque wrench for torx screw	KEY 620
M4	Adjustment screw	SCR 115
	Pin for adjusting screw	KEY 720
	Molykote	VAR 5101
Clamping torque for insert: 3 Nm		
Clamping torque for cartridge: 4 Nm		

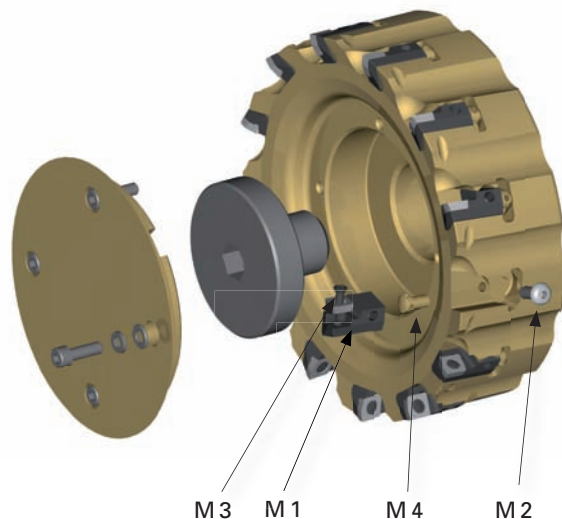

540% Increase in tool life using TFC-Solid Diamond

Application:

Milling the face of a cast aluminium oilpan. Material is a A380 Aluminium consisting of 9% silicon.

Cutting Data:

100 mm diameter cutter (Z=10)
 8000 RPM (through tool coolant)
 5420 mm/min feedrate
 1-2 mm D.O.C.
 Rz = 1,8 micron

Part life:

PDC-S = 2.500 pieces
 TFC = 13.500 pieces

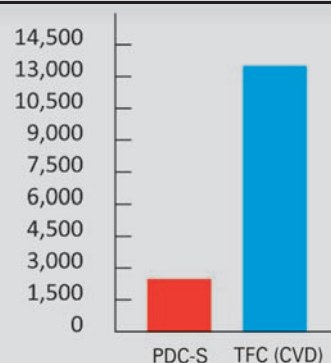



CPGW-PDR

Milling insert

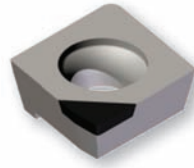

insert size	PDC-CU-S			PDC-S			PDC			TFC			MDC	dimensions					
	Neutral	CB 1	CB 2	Neutral	CB 1	CB 2	Neutral	CB 1	CB 2	Neutral	CB 1	CB 2	Neutral						
09T304PDR-1	●									●	○			9,52	4,4	3,97	9,7	4,3	0,4
09T304PDR-2	●									●	○								
09T304PDR-3	●									●	○								
09T304PDR-4	●		○							●									
09T304PDR-5	●		○							●									
09T304PDR-6	●		○							●									

Recommended application

Our 6 different milling inserts of type CPGW 09T304-PDR 1 up to type CPGW 09T304-PDR 6 differ only slightly in the respective wiper edge geometry.

However we can reach a broad application field in connection with our Diamond cutting materials TFC-Solid-Diamond und the grade PDC-CU-S.

Recommended applications				
Wiper Geometry	ap mm	fz mm	Rz μ	Remarks
PDR1	0,2-0,5	0,05-0 ,20	3 - 6	Only face-m illing, suitable for thick wall or solid workpieces
PDR2	0,1-0,4	0,04-0 ,4	1-6	Only face-m illing, suitable for thick wall or solid workpieces
PDR3	0,2 - 1,5	0,10 - 0,25	5 - 10	Face-and shoulder milling, suitable for thick wall or solid workpieces
PDR4	0,3 - 1,5	0,15 - 0,4	6 - 12	Face-and shoulder milling, suitable for thin wall or instable workpieces
PDR5	0,5 - 4,0	0,08 - 0,35	4 - 12	Face-and shoulder milling, suitable for thick wall or solid workpieces
PDR6	0,5 - 4,5	0,15 - 0,5	10 - 30	Face-and-shoulder m illing, suitable for sealing surfaces

For more information, please see page 12

Face- and Shoulder Milling Cutter 90°

Type DMEA with through coolant
Diameter 50 - 100 mm

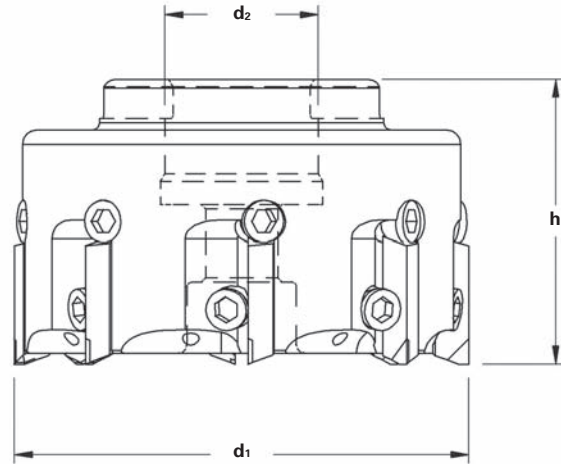

order number	dimensions						milling blades	
	d ₁ mm	d ₂ mm	h mm	flutes	RPM max. r/min	HSC max. m/min	face milling	shoulder milling
DMEA-50-5-28	50	22	40	5	10.000	1.600	BFPL 280504 BFPL 280508 BFPL 280516	BFEK 280504 BFEK 280508 BFEK 280516
DMEA-63-6-28	63	22	40	6	9.000	1.800		
DMEA-80-8-28	80	27	50	8	7.500	1.900		
DMEA-100-12-28	100	32	50	12	6.500	2.000		

For more information, please see page 13

Spare parts for milling series DiaMill-ECO: DMEA		
Illustr.	description	order-no.
M 3	Adjustment screw	JU 220
	Hexagon wrench for Adjusting screw	KEY 320
M 6	Clamping screw	JU 660
	Torque wrench for clamping screw	KEY 455
	Molykote	VAR 5101
Clamping torque for clamping screw: 4 Nm		

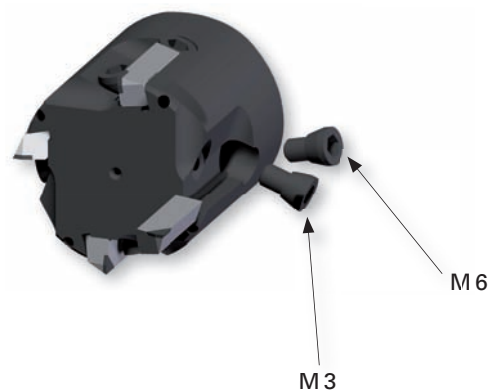

■ Face- and Shoulder Milling Cutter 90°

Type DMES, with through coolant
Diameter 25 - 50 mm

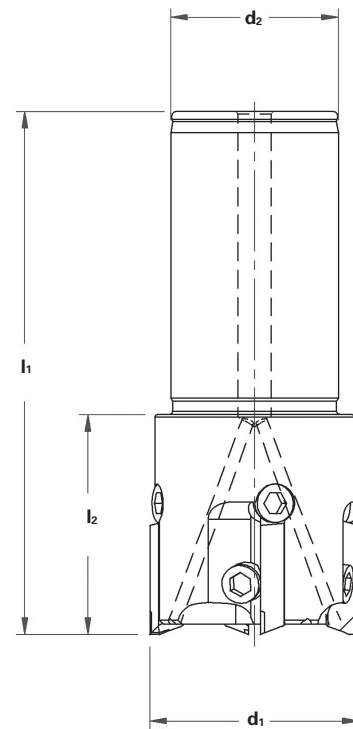
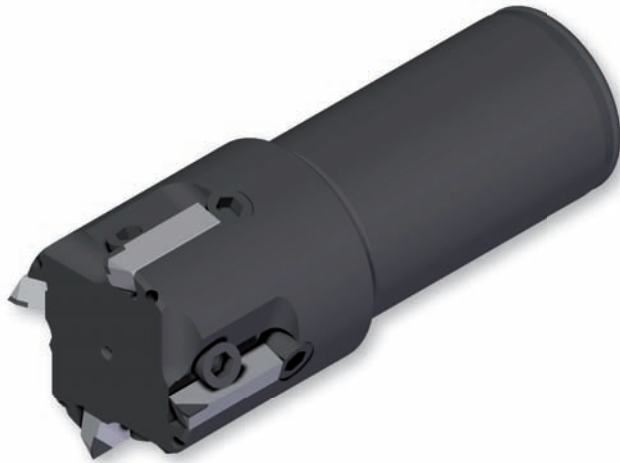

order number	dimensions							milling blades	
	d ₁ mm	d ₂ mm	l ₁ mm	l ₂ mm	Flutes	RPM max. r/min	HSC max. m/min	face milling	shoulder milling
DMES-25-2-28	25	20	100	42	2	15.000	1.200	BFPL 280504 BFPL 280508 BFPL 280516	BFEK 280504 BFEK 280508 BFEK 280516
DMES-32-3-28	32	32	100	42	3	14.000	1.400		
DMES-40-4-28	40	32	100	42	4	12.000	1.500		
DMES-50-5-28	50	32	100	42	5	10.000	1.600		

For more information, please see page 13

Spare parts for milling serie DiaMill-ECO: DMES		
Illustr.	description	order-no.
M 3	Adjustment screw	JU 220
	Hexagon wrench for Adjusting screw	KEY 320
M 6	Clamping screw	JU 660
	Torque wrench for clamping screw	KEY 455
	Molykote	VAR 5101
Clamping torque for clamping screw: 4 Nm		

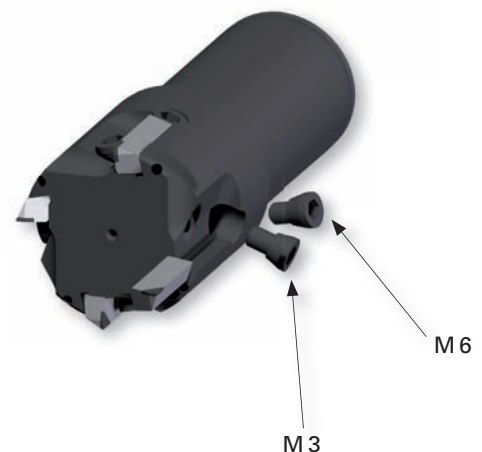

Face- and Shoulder Milling Cutter 90°

integral design HSK-A 63 and SK 40
 Type DMFS with through coolant
 fine-balanced G 2,5
 Diameter 40 - 80 mm

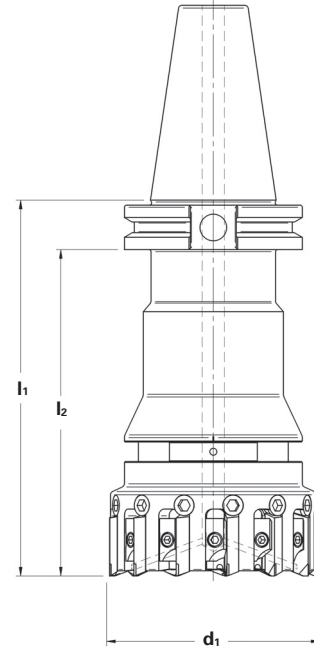
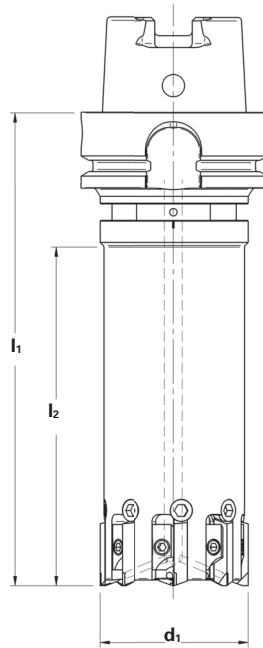
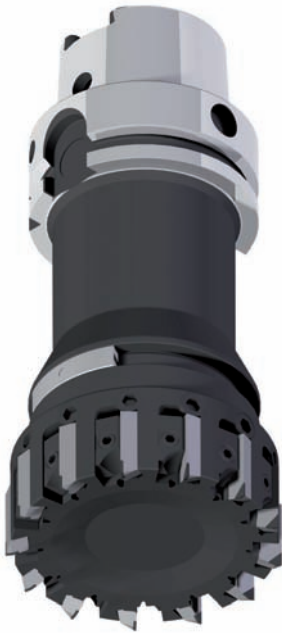

order number	dimensions							milling blades	
	d ₁ mm	l ₁ mm	l ₂ mm	tool holder	flutes	RPM max. r/min	HSC max. m/min	face milling	shoulder milling
DMFS-40-6-28-A	40	125	95	HSK-A 63	6	24.000	3.000	BFPL 280504 BFPL 280508 BFPL 280516	BFEK 280504 BFEK 280508 BFEK 280516
DMFS-50-8-28-A	50	125	95	HSK-A 63	8	22.000	3.400		
DMFS-63-10-28-A	63	125	95	HSK-A 63	10	19.000	3.700		
DMFS-80-13-28-A	80	130	100	HSK-A 63	13	17.000	4.200		
DMFS-40-6-28-K	40	125	95	SK 40	6	24.000	3.000	BFPL 280504 BFPL 280508 BFPL 280516	BFEK 280504 BFEK 280508 BFEK 280516
DMFS-50-8-28-K	50	125	95	SK 40	8	22.000	3.400		
DMFS-63-10-28-K	63	125	95	SK-40	10	19.000	3.700		
DMFS-80-13-28-K	80	130	100	SK-40	13	17.000	4.200		

Spare parts for DiaMill-FEED, see page 54

The face- and shoulder milling cutter of the DiaMill-FEED and DiaMill-FLEX types are always factory fine-balanced at G 2.5 at maximum speed (see diagrams) according to ISO 1940/1. Please bear in mind that for safety and quality reasons it is absolutely to be avoided to release and shift the balancing weights. In case of necessary follow-up balancing, please only allow for skilled staff to attend to it.

For more information, please see page 13



■ Face- and Shoulder Milling Cutter 90°

Type DMFA with through coolant
pre-balanced
Diameter 63 - 100 mm

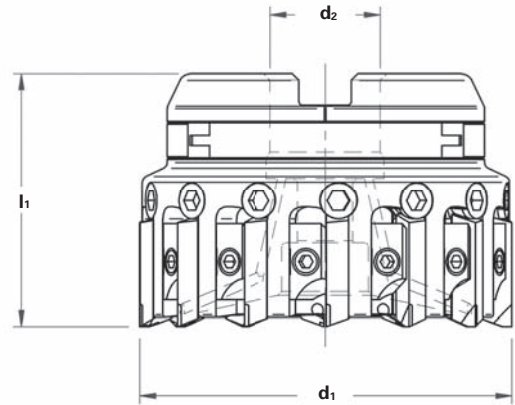

order number	dimensions						milling blades	
	d ₁ mm	d ₂ mm	h mm	flutes	RPM max. r/min	HSC max. m/min	face milling	shoulder milling
DMFA-63-10-28	63	22	55	10	19.000	3.700	BFPL 280504 BFPL 280508 BFPL 280516	BFEK 280504
DMFA-80-13-28	80	27	55	13	17.000	4.200		BFEK 280508
DMFA 100-15-28	100	32	60	15	15.000	4.700		BFEK 280516

Spare parts for DiaMill-FEED, see page 54



Balancing weight



Absolutely rigid clamping

For more information, please see page 13

■ Face- and Shoulder Milling Cutter 90°

integral design HSK-A 63 and SK 40
Type DMFL with through coolant
fine-balanced G2,5
Diameter 40 - 80 mm

Upon Request

In order to react quickly to all milling applications we offer our DMFL-series as special design to our customers. In this case the measures of length l_1 and l_2 can be determined individually.

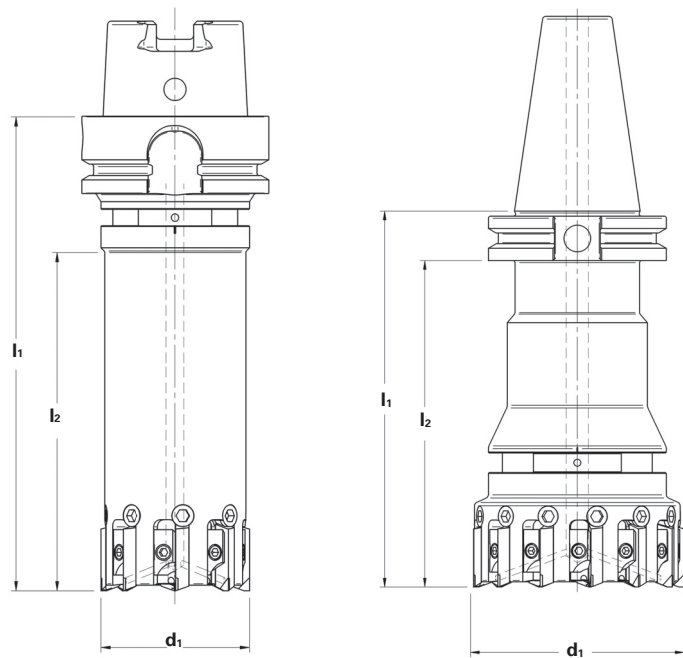
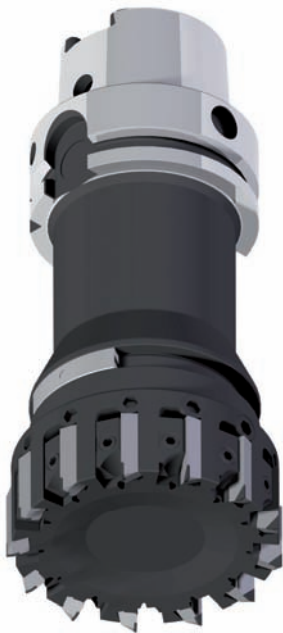

order number	dimensions							milling blades	
	d ₁ mm	l ₁ mm	l ₂ mm	tool holder	flutes	RPM max. r/min	HSC max. m/min	face milling	shoulder milling
DMFL-40-6-28-AS	40	TBS	TBS	HSK-A 63	6	24.000	3.000	BFPL 280504 BFPL 280508 BFPL 280516	BFEK 280504 BFEK 280508 BFEK 280516
DMFL-50-8-28-AS	50	TBS.	TBS	HSK-A 63	8	22.000	3.400		
DMFL-63-10-28-AS	63	TBS	TBS	HSK-A 63	10	19.000	3.700		
DMFL-80-13-28-AS	80	TBS	TBS	HSK-A 63	13	17.000	4.200		
DMFL-40-6-28-KS	40	TBS	TBS	SK 40	6	24.000	3.000	BFPL 280504 BFPL 280508 BFPL 280516	BFEK 280504 BFEK 280508 BFEK 280516
DMFL-50-8-28-KS	50	TBS	TBS	SK 40	8	22.000	3.400		
DMFL-63-10-28-KS	63	TBS	TBS	SK-40	10	19.000	3.700		
DMFL-80-13-28-KS	80	TBS	TBS	SK-40	13	17.000	4.200		

For more information, please see page 13

Spare parts for DiaMill-Flex, see page 54

■ Spare parts

for milling cutters

Types DMFA, DMFL and DMFS

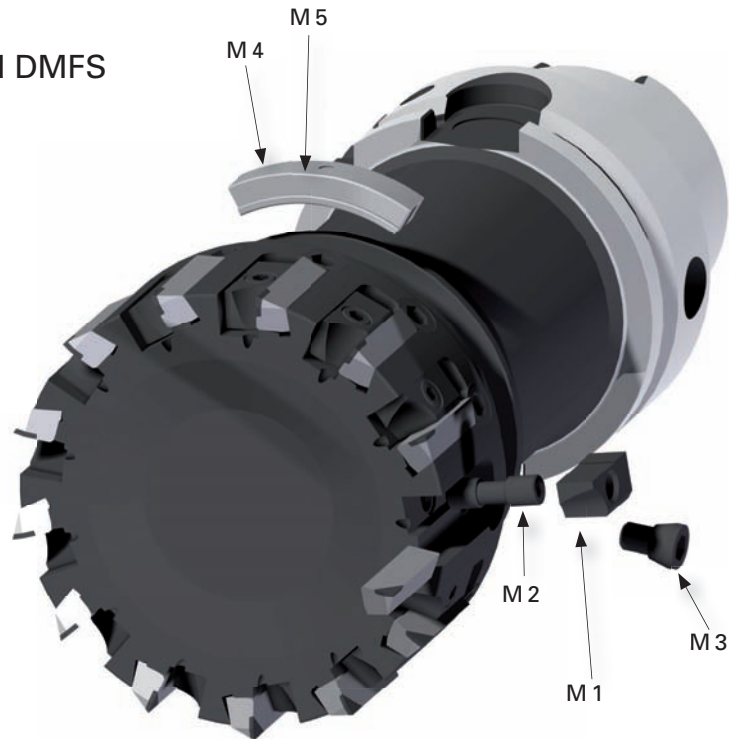

Spare parts for milling series DMFS, DMFA und DMFL

Illustr.	description	order-no.
M 1	Clamping wedge	WB 17
M 2	Screw for clamping wedge	AB 231
	Torque wrench for clamping wedge	KEY 455
M 3	Adjustment screw	JU 220
	Hexagon wrench for adjustment screw	KEY 320
M 4	balancing weight for diameter 40 mm - 3gr.	RB 2040
	balancing weight for diameter 50 mm - 3gr.	RB 2050
	balancing weight for diameter 63 mm - 6gr.	RB 2063
	balancing weight for diameter 80 mm - 7gr.	RB 2080
	balancing weight for diameter 100 mm - 8gr.	RB 20100
M 5	Screw for Balancing weight	KEY 870
	Molykote	VAR 5101
Clamping torque for wedge : 4 Nm		

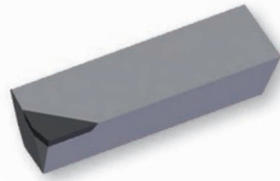

BFPL

Milling Blade, only Face milling

order number	PDC-CU-S			PDC-S			PDC			TFC			MDC	dimensions					
	Neutral	CB 1	CB 2	Neutral	CB 1	CB 2	Neutral	CB 1	CB 2	Neutral	CB 1	CB 2	Neutral	d	d ₁	s	l	l ₁	r
280504	●		●							●	●						22,6	3,5	0,4
280508	●		●							●	●							3,5	0,8
280516	●		●							●	●							3,5	1,6

V_c see page 11 f_z = 0,02 – 0,3 mm/U a_p = 0,07 – 2 mm

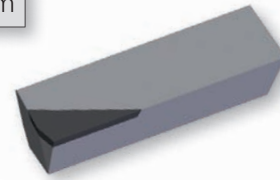

BFEK

Milling Blade, Face- and Shoulder milling

order number	PDC-CU-S			PDC-S			PDC			TFC			MDC	dimensions					
	Neutral	CB 1	CB 2	Neutral	CB 1	CB 2	Neutral	CB 1	CB 2	Neutral	CB 1	CB 2	Neutral	d	d ₁	s	l	l ₁	r
280504										●	●						22,6	5,5	0,4
280508										●	●							5,5	0,8
280516										●	●							5,5	1,6

V_c see page 11 f_z = 0,02 – 0,3 mm/U a_p = 0,1 – 4 mm

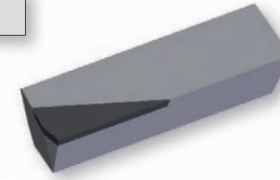

BFEK

Milling Blade, only Shoulder milling

order number	PDC-CU-S			PDC-S			PDC			TFC			MDC	dimensions					
	Neutral	CB 1	CB 2	Neutral	CB 1	CB 2	Neutral	CB 1	CB 2	Neutral	CB 1	CB 2	Neutral	d	d ₁	s	l	l ₁	r
280504	●		●														22,6	8	0,4
280508	●		●															8	0,8
280516	●		●															8	1,6

V_c see page 11 f_z = 0,06 – 0,4 mm/U a_p = 0,25 – 6 mm

We only use one single milling blade for our milling systems DiaMill-ECO, DiaMill-FEED as well as DiaMill-FLEX. The solid carbide blades are tipped with our TFC- Solid-CVD-Diamond as well as our solid PDC of grade CU-S. The superfinishing of the cutting edges is done via laser technology. The utterly stable total built of the cutter heads as well as the solid carbide milling blades enables a highly-effective material removal rate with extremely-long toolife. For more information, please see page 13



ultrahard

cutting materials

■ Trouble Shooting

Trouble shooting diamond cutting edges		
Problem	Possible cause	Suggested action
Poor surface finish	Vibration Too high feed rate Wrong diamond grade	Check rigidity of toolholder, clamping-system and machine Lower feed rate, increase nose radius or change to a wiper edge Use PDC grade with finer grain size, or use TFC or MDC
Extreme flank wear	Too high cutting speed Wrong diamond grade	Decrease speed according to cutting data tables Use PDC-grade with coarser grain size or use TFC or MDC
Edge chipping	Vibration Wrong cutting data Wrong grade	Check rigidity of toolholder, clamping system and machine Check speeds & feeds in cutting data for your application Use PDC-grade with coarser grain size (PDC-S or PDC-CU-S))
Loosen the diamond tip	Excessive cutting temperature Excessive flank wear	1. Increase coolant to tip and holder (air or fluid coolant) 2. Reduce speed and depth of cut 3. Use TFC grade
No chip breakage despite chip breaker geometry	Wrong cutting data	1. Check cutting data according to table on page 9 2. Use fluid coolant
<p>In addition to the recommendations in this catalogue, the following general rules apply to diamond cutting edge applications:</p> <ul style="list-style-type: none"> • Rigid set-up of machines and tools • Ensure best-possible coolant supply to tip due to thermal resistance of diamond up to only about 700° 		

TECHNOLOGY

TURNING

GROOVING

BORING

MILLING

**Please observe our full range
of tools with ultrahard cutting materials**

The graphic features the Becker logo (a blue diamond with 'BECKER' inside) and the text 'PcBN Cutting Tools'. Below this, there is a collection of various cutting tools including a diamond-coated drill bit, a diamond-coated reamer, a diamond-coated end mill, a diamond-coated turning tool, and a diamond-coated groove tool. A small inset image shows a silver car. At the bottom of the graphic, it lists 'SBC - PBC - Sandwich' with 'coated - uncoated' underneath, followed by a UK flag and the text 'Turning ■ Grooving ■ Boring ■ Milling' on a yellow background.

BECKER **PcBN**
Cutting Tools

SBC - PBC - Sandwich
coated - uncoated



Turning ■ Grooving ■ Boring ■ Milling

■ Imprint

© Becker Diamantwerkzeuge GmbH
Benzstraße 13
82178 Puchheim/München, Germany
all rights reserved

Tel. +49 (0) 89 02 28-0
Fax +49 (0) 89 02 28-30
sales@beckerdiamant.de
www.beckerdiamant.de

Conception and Design:
Elke Peter Marketing + Werbung, Olching
hr-design Rainer Herrmann, München

Diamond

Cutting Tools



Becker Diamantwerkzeuge GmbH

Benzstraße 13

D-82178 Puchheim / München, Germany

Tel. +49 (0)89 89 02 28-0

Fax +49 (0)89 89 02 28-30

sales@beckerdiamant.de

www.beckerdiamant.de



www.beckerdiamant.de